

Operating Instructions G-BH2

2BH20360 | 2BH20540 | 2BH20780



G-Serie
G-Series

Seitenkanal
Side Channel



1	About this manual	4
1.1	Content of this document	4
1.2	Target group	4
1.3	Explanation of the terms and symbols	4
1.4	Changes in comparison to the previous version	6
1.5	Other valid documents	6
2	Safety and responsibility	7
2.1	Explanation of warning signs	7
2.2	Correct use of the equipment	7
2.3	Improper operational modes	7
2.4	Working in a safety-conscious manner	8
2.5	Requirements for personnel	9
2.5.1	Staff qualifications and training	9
2.5.2	Personal protective equipment	10
2.6	Requirements of the operator	11
3	Product identification	12
3.1	Rating plate	12
3.2	Structure	13
3.3	Options	14
3.4	Ancillaries	14
3.5	Function principle	15
3.6	EU declaration of conformity	16
4	Transportation and storage	17
4.1	Unpacking and checking the condition of delivery	17
4.2	Lifting and transporting	17
4.3	Storage	18
5	Mounting	19
5.1	Measures after long-term storage	19
5.2	Mounting conditions	19
5.3	Reduction of oscillations and noises	20
5.4	Set up	20
5.4.1	Horizontal set-up on the foot	20
5.4.2	Vertical axis mounting on the compressor cover	21
5.4.3	Assembly on the wall or ceiling	21
5.5	Fit loose silencer and accessories	22
5.6	Connecting pipelines and hoses	22
6	Electric power connection	24
6.1	General installation regulations	24
6.2	Additional installation requirements for the drive control	25
6.3	Controls	25
6.4	Prepare the motor terminal box	26
6.5	Connect the motor to the mains	27
6.6	Connect the drive control to the mains	27
6.6.1	Connect integrated drive control 2FC4...-1ST/PB/CB/SC	27
6.6.2	Connect integrated drive control 2FC4...-1NE	27
6.6.3	Integrated drive control by third party manufacturer	28
6.6.4	Connect external drive control 2FC4...-1ST/PB/CB/SC	28
6.6.5	Connect the external drive control 2FC4...-2	28
6.6.6	Connect external drive control from third party manufacturer	28
6.7	Connect auxiliary ventilator	29

6.8	Parameterising the drive control	30
6.8.1	Parameterize integrated drive control 2FC4...-1ST/PB/CB/SC	30
6.8.2	Parameterize integrated drive control 2FC4...-1NE	30
6.8.3	Parameterize external drive control 2FC4...-1ST/PB/CB/SC	30
6.8.4	Parameterize the external drive control 2FC4...-2	31
6.8.5	Parameterize external drive control from third party	31
7	Commissioning	32
7.1	Measures after a long shut-down period	32
7.2	Tests during commissioning or re-commissioning	32
7.3	Check the direction of rotation	32
7.4	Sensors function check	33
7.5	Measure the acoustic emissions	33
7.6	Measure oscillations	33
8	Operation	34
8.1	Switch on	34
8.2	Switch off	34
8.3	Switch off in emergency	34
9	Troubleshooting	35
10	Maintenance, repairs and spare parts	38
10.1	Maintenance	38
10.2	Repairs and complaints	39
10.3	Ordering spare parts	39
11	Decommissioning	40
11.1	Decommissioning	40
11.2	Disassembly	40
11.3	Disposal	40
12	Technical data	41
12.1	Mechanical data	41
12.1.1	Weight	41
12.1.2	Connection dimensions	42
12.1.3	Tightening torque values	42
12.2	Permitted conditions for use	43
12.2.1	Installation height	43
12.2.2	Maximum speeds	43
12.2.3	Maximum temperatures	43
12.2.4	Permissible pressure differences between the suction and pressure side in operation	44
12.2.5	Pressure differences acting on the side-channel compressor	44
12.2.6	Relative humidity	44
12.2.7	Minimum distances for heat dissipation	44
12.2.8	Speed of oscillation	45
12.3	Electrical data	45
12.3.1	Increased operating cycle frequency	45
12.3.2	Parameter drive control 2FC4...-1ST/PB/PN/SC/CB	46
12.3.3	Parameter drive control 2FC4...-NE	46
12.4	Pressure differences generated by the side-channel compressor	47
12.5	Acoustic emissions	47

1.1 Content of this document

These operating instructions:

- is part of the side-channel compressor:

Series	G-BH2
Types	2BH20360--....
	2BH20540--....
	2BH20780--....

- describe the safe, proper and efficient use in all phases of its service life.
- must always be available to personnel at the place of use.
- Arranged in the main sections:
 - About these instructions
 - Safety and responsibility
 - Product identification
 - Transportation and storage
 - Mounting
 - Electric power connection
 - Commissioning
 - Operation
 - Troubleshooting
 - Maintenance, repairs and spare parts
 - Decommissioning
 - Technical data





The main section on safety must always be observed. The subsequent main sections can be used as a reference and can be read independently from each other. Cross references provided must be observed.









1.2 Target group

These instructions are aimed at operating personnel, qualified personnel, electricians, the operator and planner. See also Staff qualifications and training [→ 9].

1.3 Explanation of the terms and symbols

In these instructions symbols and terms will be used to mean the following.

Symbol	Explanation
!	Requirement, pre-requisite
①	One-step handling instructions
1 2 3	Multi-step handling instructions
✓	Result
[→ 54]	Cross reference with page reference
	Additional information, tips
	Direction of rotation arrow
	Direction of conveyance arrow
	General warning sign (warns of risk of injury)
	Electrical voltage warning

Symbol	Explanation
	Hot surface warning
	Disconnect prior to maintenance or repair
	Observe the instructions
	Use foot protection
	Use hand protection
	Use eye protection
	Use head protection
	Use ear protection
	Earth prior to use

Term	Explanation
Plant	Part provided by the user in which the side-channel compressor is installed.
Side-channel compressor = G-BH2 = vacuum pump/compressor	Ready to connect machine for the generation of a vacuum and/or overpressure. The side-channel compressor consists of a compressor and motor, as well as other accessories where applicable.
Motor	Asynchronous motor for driving the side-channel compressor.
Compressor	Mechanical part of side-channel compressor without motor.
Inner chamber of the compressor	Chamber of the compressor part that conveys media.
Substructure	Mounting plate, base frame or foundation on which the G-BH2 is constructed.
Flexible/rigid	When the lowest eigenfrequency of the system, consisting of the G-BH2 and substructure, lies at least 25% per measurement direction above the rotary frequency of the G-BH2, the substructure is considered to be rigid. All other substructures are considered to be flexible.
Assembly environment	Space in which the side-channel compressor is set up and operated (this may differ from the suction environment).
Suction/discharge environment	Chamber from which the media to be conveyed is suctioned or in which the media to be conveyed is expelled (this may differ from the assembly environment).
Single-stage	Compressor part with impeller.
Two-stage	Compressor part with two series-switched impellers. Generates higher pressure difference.
Three-stage	Compressor part with three series-switched impellers. Generates the highest pressure difference.
Vacuum operation	Operating mode whereby the - pressure at inlet $p_1 < p_{atm.}$ and - pressure at outlet $p_2 = p_{atm.}$
Compressor operation	Operating mode whereby the - pressure at inlet $p_1 = p_{atm.}$ and - pressure at outlet $p_2 > p_{atm.}$

Term	Explanation
Mixed operation	Operating mode whereby the - pressure at inlet $p_1 < p_{atm.}$ and - pressure at outlet $p_2 > p_{atm.}$
Integrated drive control = 2FC4...- 1ST/PB/PN/SC/CB	Drive control that is fitted for the G-BH2 by the manufacturer.
External drive control 2FC4...- 1ST/PB/PN/SC/CB	Drive control that is supplied by the manufacturer and is not fitted on the G-BH2 (wall assembly).
External drive control by third party manufacturer	A drive control purchased by the operator that is not fitted on the G-BH2.

1.4 Changes in comparison to the previous version

Amendments in comparison to version 07.2013

- EU declaration of conformity
- The term frequency inverter is replaced by drive control
- all drive control sections
- 1.3 Explanation of the terms and symbols
- 3.1 Data plate
- 3.5 Functional principle
- 5.4 Set-up
- 6.5 Connect the motor to the mains

1.5 Other valid documents

In addition to these instructions consider the following documents:

Document number	Purpose
610.44495.40.310	Repair manual with spare parts list and exploded view drawing 2BH20...-1
610.44495.40.320	Repair manual with spare parts list and exploded view drawing 2BH20...-2
610.44495.40.330	Repair manual with spare parts list and exploded view drawing 2BH20...-3
610.00260.40.000 *	Operating instructions integrated drive control 2FC4...-1ST/PB/PN/SC/CB OR
610.44496.40.000 *	Operating instructions for integrated drive control 2FC4...-1NE OR
610.44527.21.000 *	Operating instructions for external drive control 2FC....-2NE 3.0-11 kW OR
610.44526.21.000 *	Operating instructions for external drive control 2FC....-2NE 15-45 kW OR
— *	Operating instructions of the drive control – manufacturers
610.00110.02.000 *	Suction filter mounting instructions
610.00112.02.000 *	In-line filter mounting instructions
610.00108.02.000 *	Additional silencer mounting instructions
610.00116.02.000 *	Installation manual for the spring elements

*according to the model option or accessories

The manufacturer is not liable for damage caused by the failure to observe these instructions and the related documents [→ 6].

2.1 Explanation of warning signs

Warning sign	Explanation
⚠ DANGER	Danger that failure to observe the measures could lead to death or serious physical injuries.
⚠ WARNING	Danger that failure to observe the measures could lead to death or serious physical injuries.
⚠ CAUTION	Danger that failure to observe the measures could lead to minor physical injuries.
NOTICE	Danger that failure to observe the measures could lead to material damage.

2.2 Correct use of the equipment

The G-BH2 is a continuous operation machine that is optimised for the generation of a vacuum and pressure. The G-BH2 can be used in buildings, outside and in dusty or damp environments. The protection class is stated on the Rating plate [→ 12].

The G-BH2

- should only be used within the limits defined in this documentation. In particular, the limits in the following section must be observed:
 - Mounting conditions [→ 19]
 - Permitted conditions for use [→ 43]
 - Electrical data [→ 45]
- only operate when fully assembled and in a technically perfect condition.
- can deliver the following conveyed media:
 - air
 - All non-explosive, non-combustible, non-abrasive and non-toxic gasses and gas/air mixtures, after consultation with the manufacturer

Other operating conditions must be agreed with the manufacturer.

2.3 Improper operational modes

It is forbidden to:

- Operation in a potentially explosive area (ATEX).
- Connection in a potentially explosive area (ATEX).
- The conveyance of explosive, combustible, abrasive, unstable, oxidative or toxic media, e.g. dusts, solvents, as well as of fluids and solid matter of any type.
- Use in non-industrial plants, unless essential precautions and protective measures have been taken.
- Mobile operation.
- Reverse operation.
- Use in areas with ionising or non-ionising radiation.
- Changes to the G-BH2 and the accessories, that have not been agreed with the manufacturer.
- Operation outside of the limits defined in these instructions.
- Start-up and operation with overpressure or negative pressure from the plant.

2.4 Working in a safety-conscious manner

Work at a standstill and de-energised **Work on running or energised vacuum pumps/compressors can lead to serious injuries due to body parts being drawn in or crushed or death due to electric shock.**



Work on the G-BH2 at a standstill only and in a de-energised condition.

1. Disconnect.
2. Secure it to prevent it from being switched back on.
3. Make sure that it is de-energised.
4. Earth it and short-circuit it.
5. Cover or block off adjacent parts which are still supplied with voltage.

Hot surfaces

During operation and after decommissioning, contact with hot surfaces can lead to burns.



On the G-BH2, temperatures during operation can reach **160°C [320°F]**.

1. Do not touch hot surfaces during operation.
2. Keep hot surfaces clear of highly inflammable materials.
3. Allow the G-BH2 to cool after shutting it down.

Not fully assembled

Operation with exposed parts can lead to serious injuries due to body parts being drawn in or crushed.

1. Re-attach safety and protective devices and put them back into operation immediately after completion of work.
2. G-BH2 should only be put into operation when fully fitted.

Changes, additions and conversions

Changes, additions and conversions may lead to unforeseeable risks and thus to serious injuries or death.

Changes, additions and conversions to the G-BH2 that are not described anywhere in the documentation must be authorised by the manufacturer.

Only use original parts or parts/auxiliary materials (grease, sealant) approved by the manufacturer. Using other parts and auxiliary materials can lead to unforeseeable hazards and may exempt the manufacturer from liability for the resulting consequences.

Keep all notices attached to the G-BH2 in a clearly legible condition:

- Labelling of connections
- rotation arrows
- Rating plate
- Warning signs

2.5 Requirements for personnel

2.5.1 Staff qualifications and training



All those who will work on the G-BH2 must have read and understood these instructions and the related documents [→ 6].

Personnel in training may only work on the G-BH2 under supervision of personnel who have the **required knowledge**.

Only allow work on the G-BH2 to be carried out by personnel with the following knowledge:

Work task	Personnel	Required knowledge
Transportation, storage	Shipper, dealer, qualified personnel for transportation and storage	<ul style="list-style-type: none"> Safe handling with lifting gear such as hoists and fork lift trucks
Assembly, start-up, correcting faults, shut down, dismantling	Qualified personnel for vacuum pumps and compressors	<ul style="list-style-type: none"> Safe handling of tools Laying and connecting pipes and hoses Mounting mechanical components Knowledge of vacuum pumps and compressors
Working on the electrical system	Electrician	<ul style="list-style-type: none"> Understanding and safe implementation of circuit diagrams Lay and connect electrical lines Connection of electrical machines, switches, sensors, circuit breakers Analysing and testing electrical systems Assessing the effectiveness of electrical protection measures
Parameterising the drive control	Qualified personnel for drive controls, operators, electricians	<ul style="list-style-type: none"> Knowledge of drive controls and how to set them
Operation	Operation personnel, operator	<ul style="list-style-type: none"> Instructions for occupational safety and for handling vacuum pumps and compressors
Maintenance repair	Qualified personnel for maintenance and repair	<ul style="list-style-type: none"> Safe handling of tools and materials Disassemble and mount vacuum pumps and compressors Assess damage to vacuum pumps and compressors
Disposal	Qualified personnel for disposal	<ul style="list-style-type: none"> Decontaminating polluted materials Re-use of materials and substances Correct and environmentally-friendly disposal of materials and substances

2.5.2 Personal protective equipment



WARNING

Danger of crushing and cutting!



Crushing and cutting of body parts due to sharp edges or falling parts on the open G-BH2.



1. Wear protective gloves, safety footwear and safety goggles for all assembly and disassembly, troubleshooting and maintenance work.



2. In addition, wear head protection for transportation and overhead work.



WARNING

Risk of injury!

Serious injuries due to body parts and hair being sucked or drawn in (vacuum) or due to projected particles (pressure).

1. Wear eye protection and tight clothes for all work when in operation.

2. Wear a hair net for long hair.

3. Remove jewellery and rings.



WARNING

Hearing damage!

Hearing damage due to time spent in the excessive noise area when there are adverse operating conditions or noise due to suddenly ejected media at the discharge nozzles or piping.

① Wear ear protection when remaining in the excessive noise area.

2.6 Requirements of the operator



⚠ WARNING

Explosion and burst risk!

Any machine that is operated at a pressure or speed that is beyond that which is permitted, can explode or burst and cause serious injuries due to parts flying off and suddenly ejected conveyed media.

1. The operator must ensure that the pressure differences acting on the side-channel compressor [→ 44] are not exceeded.
2. The operator must ensure that the Maximum speeds [→ 43] are not exceeded.



⚠ WARNING

Danger of suffocation!

As the G-BH2 is not 100% leak-proof, the conveyance of media other than air can lead to suffocation.

- ① Adhere to the safety measures described for the conveyed media used (if necessary, check and monitor leakage rates).

The operator ensures that:

- All work on the G-BH2 is carried out by:
 - personnel that have the necessary Staff qualifications and training [→ 9]
 - personnel that have been sufficiently informed of these instructions and all related documents [→ 6]
- Assignment, responsibility and supervision of personnel is regulated.
- The content of these and locally applicable instructions are always available to personnel.
- Personnel are informed of the conveyed media and the emergency safety measures, so as to prevent injuries.
- All local and plant-specific safety measures are adhered to, such as:
 - Prevention of accidents
 - safety and operating regulations
 - Utility company regulations
 - Standards and laws
- Hot surfaces such as pipes and hoses are inaccessible during operation are provided with a suitable safeguard (e.g. perforated metal cover or wire covering) or are insulated.
- Hot surfaces, such as pipes and hoses, that do not have their own safeguard, are supplied with warning signs.
- The free drawing in or emission of the conveyed media does not place any personnel in danger.
- Dangers due to electrical energy are not possible.



3.1 Rating plate

Gardner Denver		A G-BH. B 2BH		C No. BN XXXXXXXX XXX /MMYY		D IEC/EN 60034 3~ Motor IP55 TH.CL.F		Q	
f [Hz]	P2 [kW]	r.p.m. [1/min]	U Δ [V]	U Y [V]	I Δ [A]	I Y [A]	Δ p [mbar]	P.F.	norm. e. eff.
E	F	G	H	H	J	J	K ₁ K ₂	L	M
50									
60								P	EXXXXXX
87									
N									Made in Germany

Gardner Denver		A G-BH. B 2BH		C No. BN XXXXXXXX XXX /MMYY		D IEC/EN 60034 3~ Motor IP55 TH.CL.F S9		Q	
motor data					rated data with converter				
E Hz	H V	J A	.. Hz .. V / .. A		.. Hz -xxx xxx mbar		K ₁ xxx mbar		K ₂ xxx mbar
F kW	P.F.	L	.. kW .. rpm		.. Hz -xxx xxx mbar		.. Hz -xxx xxx mbar		
G .. rpm									
N									Made in Germany

Gardner Denver		A G-BH. B 2BH		C No. BN XXXXXXXX XXX /MMYY		D IEC/EN 60034 3~ Motor IP55 TH.CL.F		Q	
50 Hz	E	H V	J A Δ	60 Hz	V	A Δ			
.. kW	F	V	A Y	.. kW	V	A Y			
G .. / min	V / A Δ		.. / min		V / A Δ				
K ₁ -xx		K ₂ xx mbar		-xxx xxx mbar					
N									Made in Germany

Gardner Denver		A G-BH. B 2BH		C No. BN XXXXXXXX XXX /MMYY		D IEC/EN 60034 3~ Motor IP55 TH.CL.F		Q	
50 Hz	E	.. kW	F	60 Hz	.. kW	87 Hz	.. kW		
G .. / min	.. / min		.. / min		.. / min				
H	V	J A Δ	V / A Δ		V / A Δ				
K ₁ -xx		K ₂ xx mbar		-xxx xxx mbar					
N									Made in Germany

- A Series
- B Type
- C Serial number/year of manufacture
- D Machine type, protection class, thermal class
- E Frequency
- F Motor output power
- G Rated rpm
- H Delta/star voltage
- J Delta/star current

- K Pressure differences
 - K₁ values with a negative sign apply to vacuum and vacuum operation
 - K₂ values with no sign apply to overpressure and compressor operation
- L Power factor
- M Nominal efficiency level and efficiency class according to EN 60034-70
- N Manufacturer's recommendations, customer information (optional)
- P UL and CSA recognition mark + UL file number (optional)
- Q Serial number/year of manufacture as QR code

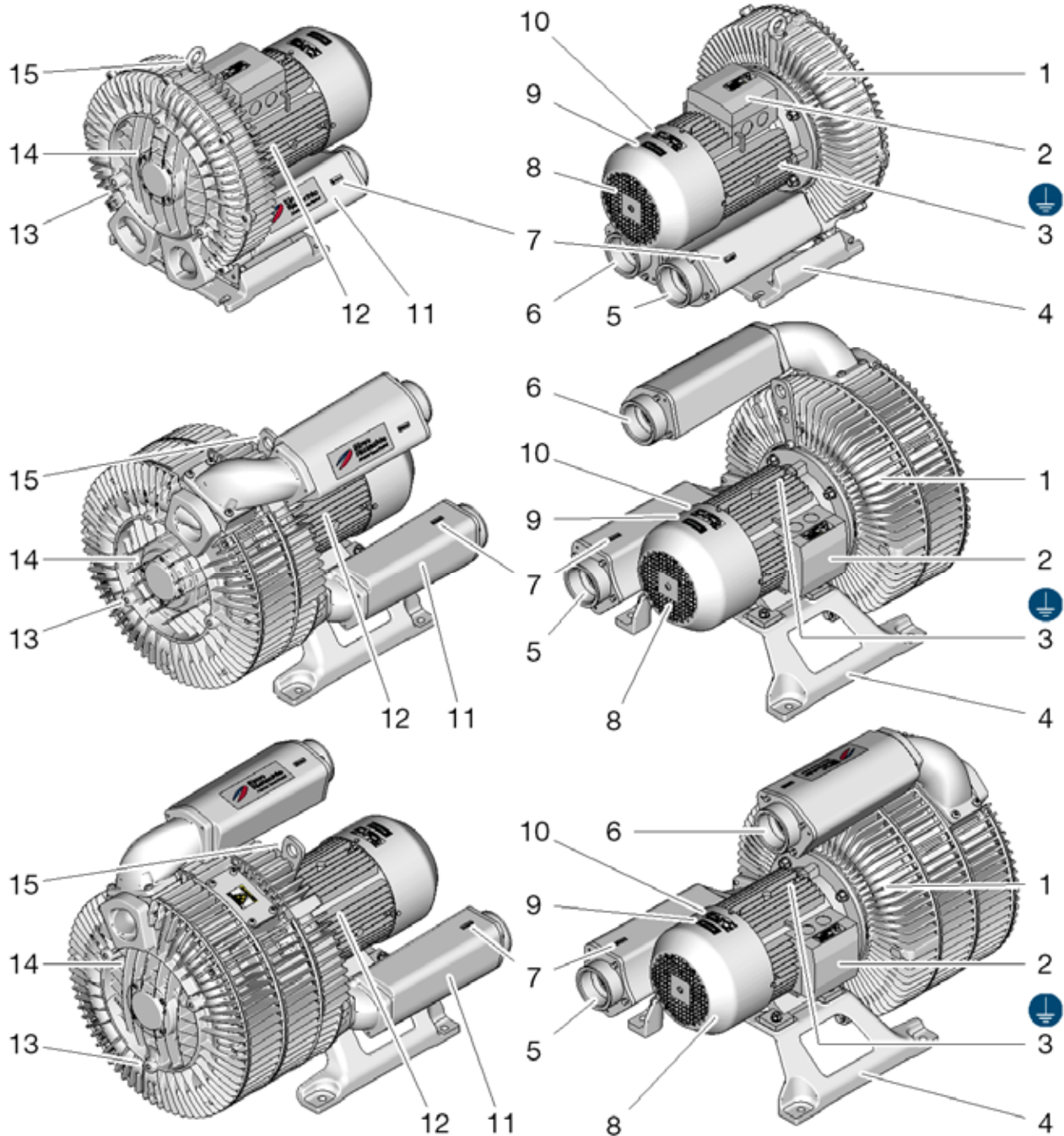
3.2 Structure

- | | | | |
|---|-------------------------------|----|-----------------------------------|
| 1 | Compressor housing | 9 | Direction of rotation arrow |
| 2 | Terminal box | 10 | Rating plate |
| 3 | Earth connection | 11 | Silencer |
| 4 | Foot | 12 | Asynchronous motor |
| 5 | Discharge-side connection | 13 | Threaded holes for cover position |
| 6 | Suction side connection | 14 | Compressor cover |
| 7 | Direction of conveyance arrow | 15 | Eye bolt/lifting attachment |
| 8 | Fan guard | | |

3.3 Options

The G-BH2 can be delivered with the following options

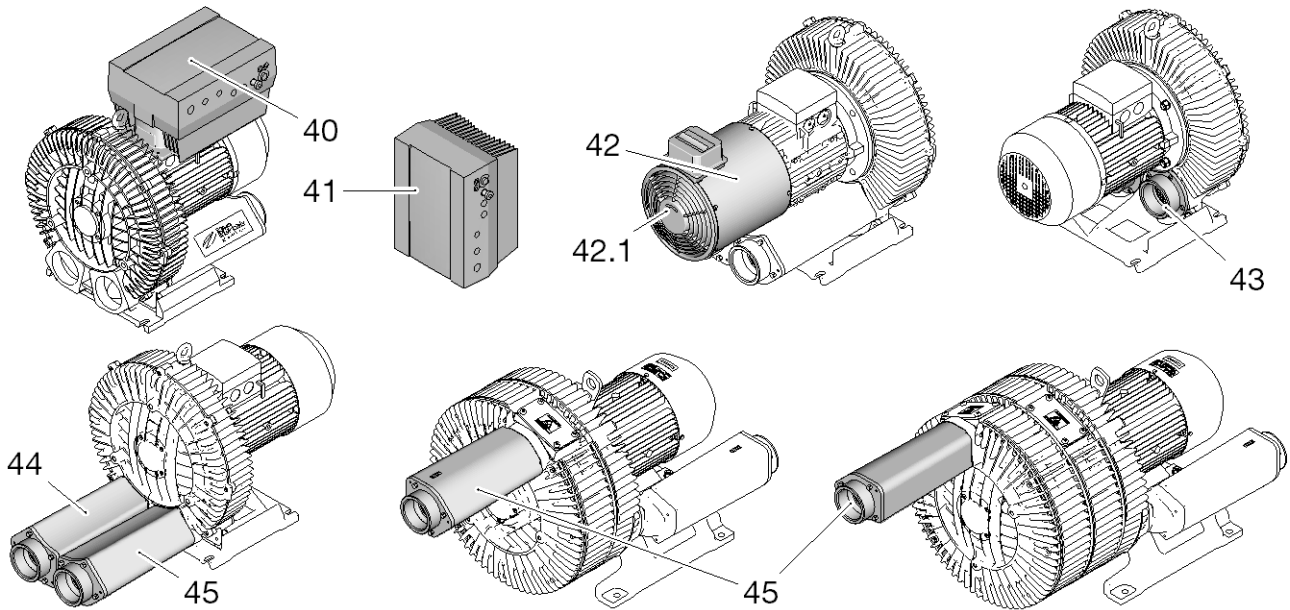

- | | | | |
|------|---|----|---|
| 40 | Integrated drive control 2FC4...-1ST/PB/PN/SC/CB | 43 | Discharge side and/or suction side without silencer with flange |
| 41 | Wall assembly drive control 2FC4...-1ST/PB/PN/SC/CB | 44 | Discharge side and/or suction side, cover side |
| 42 | Auxiliary ventilator | 45 | Suction side, cover side |
| 42.1 | Direction of rotation arrow, auxiliary ventilator | | |

3.4 Ancillaries

The following original accessories are available from the manufacturer

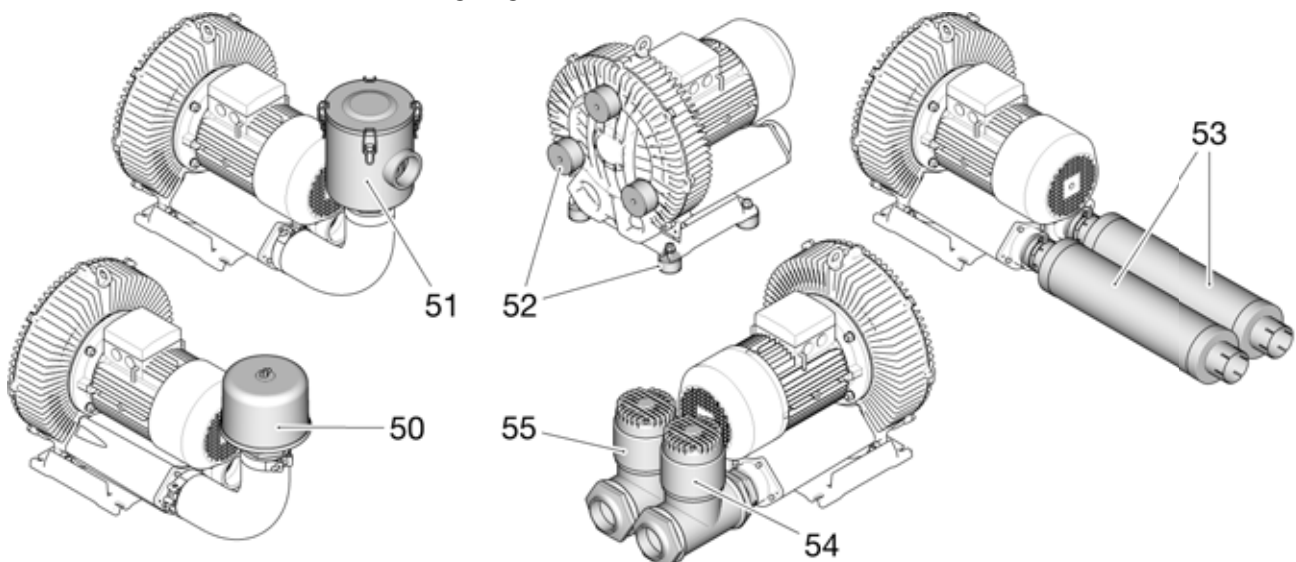

- | | | | |
|----|----------------|----|-------------------------|
| 50 | Suction filter | 53 | Additional silencers |
| 51 | In-line filter | 54 | Pressure limiting valve |
| 52 | Spring mounts | 55 | Vacuum shut-off valve |

3.5 Function principle

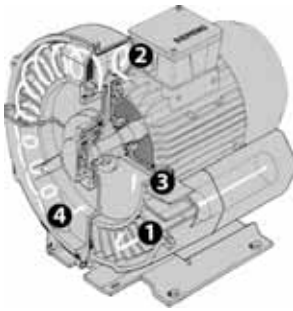

The side-channel compressor consists of a drive (motor) and a compressor part in which an impeller rotates contact-free in the side-channel.

Side-channel compressors can be used as a vacuum pump or are used as the compressor (observe Correct use of the equipment [→ 7]).

As soon as the motor is switched on, conveyed media is suctioned on the suction side connection (1).

When it enters the side-channel the conveyed media is accelerated in the direction of rotation by the blades of the rotating impeller (3).

The centrifugal force presses the conveyed media to the inner wall of the side-channel (2). From there, the conveyed media is supplied to the impeller blades again.

With every renewed entry of the conveyed media into the impeller, it gains kinetic energy and the pressure increases.

The cross section of the side-channel is limited at the interrupter.

In this manner, the conveyed media is stripped from the impeller blades and expelled via the discharge-side connection (4).

3.6 EU declaration of conformity

EU declaration of conformity



Manufacturer: Gardner Denver Deutschland GmbH
 Industriestraße 26, 97616 Bad Neustadt, Germany

Representative for the compilation of technical documents: Holger Krause
 Industriestraße 26, 97616 Bad Neustadt, Germany

Designation of the machine: G-Series Side Channel Compressor

Series	G-BH2
Types	2BH20360- - ...
	2BH20540- - ...
	2BH20780- - ...

The machine described above meets the following applicable Community harmonisation legislation:

2006/42/EC European Parliament and Council Directive 2006/42/EC from 17th May 2006 on machinery and amending Directive 95/16/EC.

2004/108/EC Directive 2004/108/EC of the European Parliament and Council from 15th December 2004 for the application of the legal regulations of the EU member states concerning electrical devices and repealing Directive 89/336/EEC

Harmonised standards applied:

EN 1012-1:2010 Compressors and vacuum pumps - Safety requirements - Part 1: Compressors

EN 1012-2:1996 +A1:2009 Compressors and vacuum pumps - Safety requirements - Part 2: Vacuum pumps

EN ISO 12100:2010 Safety of machinery - General principles for design - Risk assessment and risk reduction (ISO 12100:2010)

EN 60204-1:2006 Safety of machinery - Electrical equipment of machines Part 1: General requirements IEC 60204-1:2005 (amended)

EN 60034-1:2010/ AC: 2010 Rotating electrical machines - Part 1: Rating and performance IEC 60034-1:2010 (amended)

Bad Neustadt, 28.02.2014
(Place and date of issue)



Andreas Bernklau, Product management/Authorised signatory
(Name and function)



Dr. Rudi Dittmar, Development
(Name and function)

664.44495.40.000

4.1 Unpacking and checking the condition of delivery

The G-BH2 is secured onto a pallet or foot plate and protected by a cardboard box for delivery.

1. Remove the packaging.
NOTICE! First remove the transport protection on the connection openings before connecting the pipes and hoses.
2. Check the G-BH2 for transport damage.
NOTICE! Report any transport damage to the manufacturer immediately.
3. Check that the G-BH2 delivered complies with the order.
4. Check that accessories delivered with it are complete.
5. Loosen the fixing screws on the foot (item 4, Structure [→ 13]).
6. Dispose of packaging material in accordance with the valid local regulations.

4.2 Lifting and transporting

 **WARNING**

Danger of crushing and cutting!

Danger of crushing and cutting of body parts due to tipping or falling loads during transportation.

1. The G-BH2 may only be transported horizontally.
2. The load-bearing capacity of the lifting gear and load-handling devices must correspond to the mass [→ 41] of the G-BH2.
3. Secure the G-BH2 to prevent it from toppling or falling.
4. Do not remain under supported loads.
5. Set the G-BH2 down on a horizontal surface.

NOTICE

Mechanical damage!

G-BH2 can be damaged during transportation due to impacts, tipping or falling over.

1. The G-BH2 should not be exposed to impacts and blows during transportation.
✓ maximum linear acceleration: 1g
2. Secure the G-BH2 from tipping or falling over.

Preparing the G-BH2 for transportation

The G-BH2 on the compressor cover (item 14, Structure [→ 13]) must be placed horizontally on the compressor foot before transportation (item 4, Structure [→ 13]).

1. Place the lifting strap between the compressor housing (item 1, Structure [→ 13]) and foot around the motor (item 12, Structure [→ 13]).
2. Lift the G-BH2 until the lifting strap is taut.
3. Tilt the G-BH2 with two people on the compressor foot.

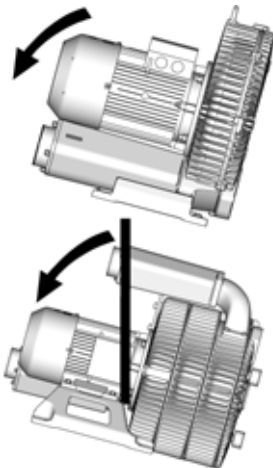

Transportation with a crane



! All single-stage G-BH2 are equipped with an **eye bolt** (item 15, Structure [→ 13]) and all two and three-stage G-BH2 are equipped with a **lifting attachment** (item 15, Structure [→ 13]). The eye bolt or lifting attachment is exclusively designed for the mass of the G-BH2, including the original accessories (except for the in-line filter, item 51, Structure [→ 13]).

1. Detach the fitted in-line filter before transportation of the G-BH2.
2. Check that the eye bolt or lifting attachment is firmly fastened and retighten as necessary.
 - ✓ Tightening torque of eye bolt: M12 **18 - 22 Nm** [13.3 - 16.2 ft lbs].
3. Attach the crane hook to the eye bolt or lifting attachment.
4. Lifting and transporting the G-BH2.
5. Place the G-BH2 down and, if necessary, secure from slipping and falling.
6. Remove the crane hook after transportation.

4.3 Storage

NOTICE

Mechanical damage and corrosion!

Failure to adhere to the storage conditions can lead to mechanical damage and corrosion or can shorten the re-greasing interval.

1. Adhere to the storage conditions.
 2. The maintenance intervals of the ball bearings (Maintenance [→ 38]) become shorter as the time of storage increases.
-
1. Connect all suction vents so that no dirt or solid particles can enter.
 2. Turn the rotor once per year so as to avoid permanent standstill marks.

Storage and standstill conditions	permitted values	
ambient pressure	atmospheric	
composition of the environment	dry, dust-free atmosphere (relatively humid < 60%)	
Ambient temperature	-20°C to +40°C	-4°F to +104°F
static impacts	none	
jerky impacts	none	
Speed of oscillation V_{eff}	<1.5 mm/s	<0.059 in/s

5.1 Measures after long-term storage

Replace ball bearings and radial shaft seal

! When the length of storage until assembly is exceeded by **4 years** for the storage conditions provided in Storage [→ 18].

1. Replace the rolling bearing.
2. Clean adjacent bearing areas for open ball bearings and re-grease.
3. Replace and grease the radial shaft seal.

If the bearing conditions vary (Storage [→ 18]), a reduced ball bearing service life is to be expected.

Measuring the motor insulation resistance

- ① Measuring the motor insulation resistance.
 - ✓ Value $>1 \text{ k}\Omega$ per volt of measured voltage: no measures necessary.
 - ✓ Value $\leq 1 \text{ k}\Omega$ per volt of measured voltage: Dry winding.

5.2 Mounting conditions

At the place of assembly,

- Adhere to the Permitted conditions for use [→ 43].
- No outlet air from other machines in the suction area of the motor fan or auxiliary ventilator.
- Provide ventilation facilities, so that the permissible Maximum temperatures [→ 43] are not exceeded.
- Sufficient room is provided for installation and removal of pipelines and maintenance and repair work, particularly for removing and installing the G-BH2.
- Provide an even, stable installation surface or base frame whose dimensions and load-bearing capacity are designed for the G-BH2.
- The maximum tolerance for the evenness of the assembly surface is **0.5 mm** [0.197 in].
- External oscillations **$>1.5 \text{ mm/s}$** [0.06 in/s], linear accelerations **$>3 \text{ m/s}^2$** [9.85 ft/s²] as well as shock loads or rotary accelerations are not permitted.
- When installing outdoors, protective measures against the effects of weather such as rain, direct sunlight, lightening, snow or ice (e.g. a protective roof) must be provided.
- External mechanical loads are not permitted on the G-BH2 and its attachments (e.g. piping without support, ascending the G-BH2 and its attachments)
- For installation in enclosed spaces and for conveyed media other than air, leaks from the G-BH2 must be considered.
- When operating without silencers and direct extraction from the environment or direct discharge into the environment, effective noise protection measures must be provided.
- When there is a risk of condensation formation in the internal space of the G-BH2, provide suitable protection measures (e.g. heating, upstream moisture separators, continue running G-BH2).
- For G-BH2 with a condensate drain hole, the condensate can always escape freely under the fan guard (item 8, Structure [→ 13]). If necessary, provide suitable measures to prevent condensate from escaping.

5.3 Reduction of oscillations and noises

Noise emissions and vibrations can be reduced by the following measures.

- Do not set up the G-BH2 in set-up areas that conduct or radiate sound.
- Equip installation surfaces with intermediate layers of noise damping material.
- Use additional silencers (accessory).
- Use spring elements (accessory) for horizontal assembly.

It is recommended to flexibly set up the G-BH2 on springs elements.

5.4 Set up

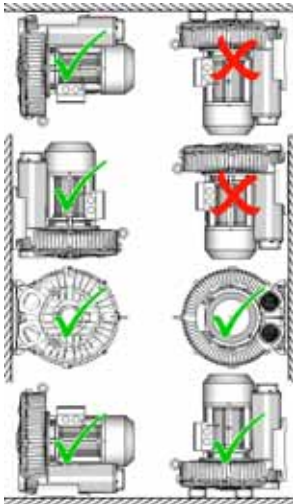

The G-BH2 must always be screwed to a fixed installation surface (e.g. floor, wall, ceiling) or a base frame.

The following assembly options are permitted:

- Horizontal assembly on the foot (item 4, Structure [→ 13]).
- Vertical assembly on the compressor cover (item 14, Structure [→ 13]).
- Assembly on the wall or ceiling:
 - Hanging horizontally on the foot:
 - Hanging vertically on the foot with the compressor cover facing downwards

Exceptions

- 2BH20...-...N/1/2/3/4 may only be assembled horizontally on the foot.
- 2BH20780-2A..P/Q/R and 2BH20780-3A..P/Q/R may only be assembled horizontally on the foot.

Condensate drain hole

The function of the condensate drain hole is only guaranteed when it is mounted horizontally on the foot.

5.4.1 Horizontal set-up on the foot

1. Mark the fixing points through the holes in the foot (item 4, Structure [→ 13]) or referring to the dimensional drawing.
2. Lift the G-BH2 away and drill the holes for the fixing points.
3. Place the G-BH2 with the foot in assembly position.
4. Screw the foot to all anchorage holes with suitable fastening elements.

5.4.2 Vertical axis mounting on the compressor cover

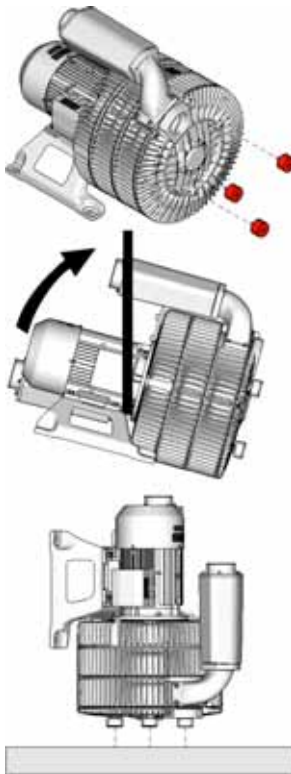

! For vertical mounting on the compressor cover (item 14, Structure [→ 13]), spring elements (accessory) must be used.

1. Mark the threaded holes for the cover position (item 13, Structure [→ 13]) referring to the dimensional drawing.
2. Drill the holes for the fixing points.
3. Screw the threaded studs of the spring elements into the threaded holes for the cover position.
⚠ CAUTION! Tighten hand-tight! Tightening torque 11 - 22 Nm (8.1 - 16.2 ft lbs)
4. Place the lifting strap between the compressor housing (item 1, Structure [→ 13]) and foot (item 4, Structure [→ 13]) around the motor (item 12, Structure [→ 13]).
5. Lift the G-BH2 and tilt it with **two** people on the compressor cover.
6. Place the G-BH2 with the compressor cover in assembly position.
7. Screw G-BH2 securely to mounting surface using threaded hole in spring elements and suitable securing element.
8. Remove lifting strap.

5.4.3 Assembly on the wall or ceiling

⚠ WARNING

Danger of crushing and cutting!

Danger of crushing and cutting of body parts due to falling G-BH2 as a result of incorrect assembly.

1. Fit the G-BH2 exclusively on the **foot without spring elements**.
 2. Fit the G-BH2 for vertical assembly on the wall exclusively with the **compressor cover (item 14, Structure [→ 13]) facing downwards**.
-
1. Mark the fixing points of the foot (item 4, Structure [→ 13]) referring to the dimensional drawing.
 2. Drill the holes for the fixing points.
 3. Place the G-BH2 securely in assembly position with corresponding means of transport and keep it there.
 4. Secure the foot of the G-BH2 to the installation surface using suitable securing devices.
Do this by inserting bolts into all anchorage holes.
 5. Measures to protect against falling parts provided.

5.5 Fit loose silencer and accessories

Fit loose silencer

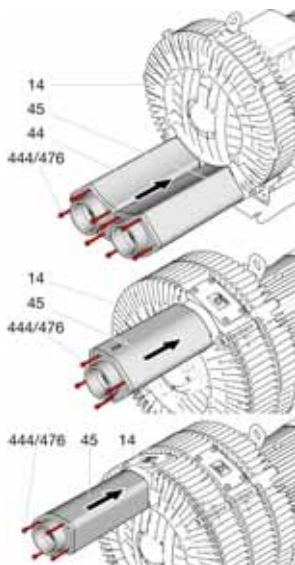

! For G-BH2 with discharge/suction side on cover side, the silencers are enclosed separately due to technical packaging reasons and must be fitted.

1. Remove transport protection.
2. Position the silencers (item 44/45) on the compressor cover (item 14) and screw in with nuts (476) and threaded studs (444).

Mount the accessories

- ① Fit accessories included separately on the G-BH2 according to the enclosed owner's manual.

5.6 Connecting pipelines and hoses

⚠ WARNING

Risk of injury due to overpressure!

Suddenly ejected conveyed media such as impurities and solid particles or pressure surges can lead to serious injuries.

1. Dimension pipes and hoses, securing elements, fittings and containers sufficiently and align them to the maximum pressures.
2. Connect the G-BH2 and the system de-energised and flexibly (e.g. using hoses or compensators).
3. Do not fit pipes, hoses, securing elements, fittings and containers to the G-BH2 and secure from damage.
4. Prevent the entry of solid particles and fluids in the G-BH2 (clean pipes and hoses after assembly, use an extraction or in-line filter if necessary).
5. Protect the G-BH2 from non-permitted pressure levels from the plant (e.g. pressure limiting valve, pressure switch).
6. For compressor operation, the pressure on the pressure connectors of the G-BH2 must be monitored using a suitable pressure indicator. When the permissible discharge pressure is exceeded, switch the G-BH2 off.
7. After switching off, ensure that no conveyed media can flow through the G-BH2 (uncontrolled speed by conveyed media), install a check valve if necessary.
8. With a free-blowing pressure side, secure the danger area from hot conveyed media and projected particles with deflection plates or a collection basket.

 **WARNING**

Serious injuries due to suction and drawing in of body parts and hair during compressor operation!

- ① For free drawing in from the environment, provide safety measures that prevent the drawing in of body parts and hair.

 **WARNING**

**Risk of burns due to temperatures of up to approx. 160°C [320°F]!
Contact with hot surfaces, pipes and hoses, can lead to burns.**

1. Fit pipes and hoses with sufficient distance from highly inflammable materials (e.g. wood, plastic).
2. Provide hot surfaces, such as pipes and hoses with a suitable safeguard (e.g. perforated metal cover or wire covering) or isolate them.
3. Hot surfaces, such as pipes and hoses, that do not have their own safeguard, are supplied with warning signs.

NOTICE

Pressure loss due to reduced cross section of the pipes and hoses!

- ① As possible, make the cross section of the pipes and hoses the same length or longer than the connections of the G-BH2.

The conveyed media is suctioned via the suction side (item 6, Structure [→ 13]) and expelled via the pressure side (item 5, Structure [→ 13]). The direction of conveyance of the conveyed media is marked by an arrow (item 7, Structure [→ 13]).

The G-BH2 can be fitted with pipes or hoses (internal threads).

! On delivery, all connection openings are closed with a transport protection. This prevents foreign objects from entering.

1. Remove the transport protection from the connection openings.
2. If the pressure connector of the G-BH2 is not connected with a pipe or a hose, the customer must provide sound protection measures or personal protective equipment.
3. For impurities in the conveyed media, fit a filter (accessories) in the suction line.
4. Connect the pipe or hose of the system pressure line to the discharge side connection (item 5, Structure [→ 13]).
5. Connect the pipe or hose of the system suction line to the suction side connection (item 6, Structure [→ 13]).

6.1 General installation regulations



⚠ DANGER

Lethal electric shock on the housing due to the air gap being too small!

! Air gaps between non-insulated, voltage active components and the earth must be at least **5.5 mm** [0.217 in] to one another (for a measured voltage of $U_N \leq 690$ V).

1. Avoid projecting cable ends.
2. Ensure electrical connections are durably resilient.



⚠ DANGER

Lethal electric shock due to contact voltage on the housing!



1. Implement protection from contact voltage according to IEC 60204-1. Use the earth connection in the terminal box (equipotential bonding protection). For operating the drive control, observe the manufacturer's operating instructions for the drive control.
2. If necessary, connect the equipotential bonding function to the second earth connection (item 3, Structure [→ 13]).
3. Keep the terminal box free of foreign objects, dirt and moisture.
4. Seal terminal box lid and cable feed openings so that they are dust and water tight.

NOTICE

Mains operation with a non-earthed star point can destroy the G-BH2!

- ① Mains operation of the G-BH2 with a non-earthed star point is not permitted.

NOTICE

Destruction of the asynchronous motor due to incorrect electrical operation or incorrect control!

! The G-BH2 is equipped with an **asynchronous motor**.

- ① Adjust the electrical operation and control to the asynchronous motor.

The electrical installation must correctly fulfil the requirements of IEC 60204-1, IEC 60204-11 and IEC 61010-1 in accordance with the ambient and operating conditions.

The electrical installation must also be implemented according to the applicable national, local and plant-specific stipulations, as well as the requirements of the power supply company.

The conditions at the place of use must comply with the details on the Rating plate [→ 12] and if necessary, with the drive control. Permissible deviations for mains operation according to EN 60034-1 (range A) without loss of performance:

- $\pm 5\%$ variation in voltage
- $\pm 2\%$ deviation in frequency

The electrical installation must:

- Be correctly attached and protected.
- Be kept away from hot surfaces.
- Be electrically isolated to a sufficient degree.

- Be constructed and fitted in such a way that the following faults do not lead to damage:
 - short circuits
 - mechanical impacts
 - power supply failures or surges
 - electromagnetic fields
 - earth connections

The electrical equipment and control must not put the protective devices of the drive system and the motor protection (e.g. PTC resistor, bimetal switch, frequency inverter current limit) out of operation.

When the power supply fails or surges, the control must prevent the G-BH2 from remaining in operation or starting up.

Protective devices and switches must fulfil the failure safety conditions.

Overcurrent protection

The power supply of the motor and, if necessary, of the auxiliary ventilator must be equipped with an overcurrent protection according to IEC 60204-1, 7.2. Electrical data, see Rating plate [→ 12].

Separator for the electrical energy supply

A separator for the electrical energy supply must be provided and:

- implemented according to IEC 60204-1, 5.3 and 5.5 (for electrical data, see Rating plate [→ 12]).
- The separator for the electrical energy supply must be clearly and visibly marked.

6.2 Additional installation requirements for the drive control

NOTICE

Destruction of the isolation system due to excessive drive control voltages!

! The standard isolation system of the motor is designed for drive control input voltages of up to 460 V, and drive control output voltage rise times $> 0.1 \mu\text{s}$.

- ① For higher input voltages or shorter rise times, special measures must be taken, such as an output filter.

When establishing the electrical connection of a drive control:

- Connect the PTC resistor, when the PTC resistor is activated, the G-BH2 must switch off.
- Manufacturer's operating instructions for the drive control.

6.3 Controls

Controls and instruments must be constructed and arranged in such a way that:

- They are easily visible and accessible, and can also be operated without excessive effort.
- The operating personnel understand the functions.
- Operating faults are prevented.

A control system must correspond to ISO 12100, 4.11; IEC 60204-1, 9.4 and ISO 13849-1.

When the power supply fails, a "system with oriented failure mode" according to ISO 12100, 6.2.12.3 must be used.

Start and stop devices must be clearly marked in accordance with ISO 13850 and IEC 60417.

EMERGENCY OFF function

An EMERGENCY OFF function must be provided when a dangerous situation can occur that must be rectified manually (see ISO 12100, 5.5.2)

- Implement the EMERGENCY off function according to EN 418 and EN 50099.
- Implement a manual EMERGENCY OFF function according to ISO 13849-1, 5 (in particular 5.2.1).
- The stop category and colour of the EMERGENCY OFF function must correspond to ISO 13850.
- If a risk assessment determines that the normal switch can fulfil the EMERGENCY OFF function, this should be labelled accordingly.

After an EMERGENCY OFF, start-up is only possible via a deliberate, manually-triggered procedure.

Manual reset

A manual reset after a stop command must correspond to ISO 13849-1, 5.5.2 and IEC 60204-1, 9.2.5.3 and 9.2.5.4.

Start and new start

The requirements of a start and new start, must correspond to ISO 13849-1, 5.2.3.



If the G-BH2 is equipped with an automatic or remote-controlled start control, it must be labelled with the sign to the left.

An automatic or remote-controlled start during maintenance or repair must be prevented by a latch, which is contained in the control system (e.g. key transfer system or protected password for software-controlled systems).

6.4 Prepare the motor terminal box

This section does not apply to G-BH2 with integrated drive control 2FC4...-1 (item 40, Options [→ 14]).

1. Remove the blind plugs.
OR
carefully knock the scale out.

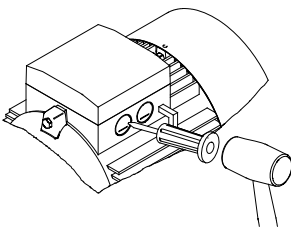

2. Insert screw fittings.
Fit reducer when using a positive temperature coefficient (PTC) resistor.

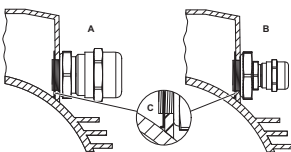

6.5 Connect the motor to the mains



1. Open the terminal box cover.
2. Connect the protective cable to the terminal with the symbol to the left.
3. Connect switch stirrup according to circuit diagram in (item 2, Structure [→ 13]).

Note torque settings for terminal plate connections.

For connections with a terminal clip, route the conductor so that both pin ends are at approximately equal clip height.

Earth conductor and exterior earth conductor must be bent into a "U" shape. All other conductors must be bent into a "U" shape or connected using a suitable terminal end.

4. Connect PTC resistor, bimetal switch and rest period according to the circuit diagram in the terminal box (item 2, Structure [→ 13]). Use a suitable PTC resistor evaluation unit for the evaluation of the PTC resistor.
5. Close the terminal box cover.

6.6 Connect the drive control to the mains

NOTICE

Failure to reach the pressure values due to insufficient voltages on the motor terminal board!

! The voltages given on the rating plate (item HRating plate [→ 12]) apply to mains operation.

- ① For operation of the G-BH2 on the drive control, the voltages given on the rating plate must be adhered to on the motor terminal board.

NOTICE

G-BH2 with UL approval may not be operated in the USA without testing of the drive control by a suitable testing agency!

- ① G-BH2 must be certified by a suitable testing agency or operated without a drive control.

Observe when operating with drive control

- The G-BH2 is equipped with an asynchronous motor and must be controlled correspondingly.
- For G-BH2 with installed sensors (e.g. PTC resistor), there is a possibility of interfering voltages occurring in the sensor wiring, but this depends on the type of drive control.
- Observe [→ 43] revolution limits.

6.6.1 Connect integrated drive control 2FC4...-1ST/PB/CB/SC

- ① Connect integrated drive control 2FC4...-1ST/PB/PN/SC/CB (item 40, Options [→ 14]) according to the related operating instructions [→ 6].

6.6.2 Connect integrated drive control 2FC4...-1NE

- ① Connect integrated drive control 2FC4...-1NE (item 40, Options [→ 14]) according to the related operating instructions [→ 6].

6.6.3 Integrated drive control by third party manufacturer

NOTICE

Mechanical damage!

Integrated drive controls from third-party manufacturers can overload the foot and lifting attachment or damage the bearing due to the oscillations.

- ① Do not fit integrated drive controls from third-party manufacturers on the G-BH2.

6.6.4 Connect external drive control 2FC4...-1ST/PB/CB/SC

1. Open the terminal box cover of the motor (item 2, Structure [→ 13]).
2. Connect drive control **2FC4...-1ST/PB/PN/SC/CB** (item 41, Options [→ 14]) according to the related operating instructions [→ 6].
3. Close the terminal box cover.

6.6.5 Connect the external drive control 2FC4...-2

1. Open the terminal box cover of the motor (item 2, Structure [→ 13]).
2. Connect drive control 2FC4...-2 (item 41, Options [→ 14]) according to the related operating instructions [→ 6].
3. Close the terminal box cover.

6.6.6 Connect external drive control from third party manufacturer

Observe when operating with an external drive control

- High-frequency current and voltage harmonics in the motor supply wiring can cause electro-magnetic interference. This is dependent on the type of drive control (type, manufacture, voltage supply measures).
 - Observe manufacturer's EMC notes for the drive control.
 - If necessary, use screened cables/wiring. To provided the optimum screening, the screening must be connected to the metal terminal box using a large-area metal conducting fastener.
1. Open the terminal box cover of the motor (item 2, Structure [→ 13]).
 2. Connect electrical cabinet inverters according to the circuit diagram in the motor terminal box cover and the manufacturer's operating instructions for the drive control.
 3. Connect the PTC resistor according to the following examples.
 4. Close the terminal box cover.

Circuit diagram with suitable PTC resistor and evaluation unit

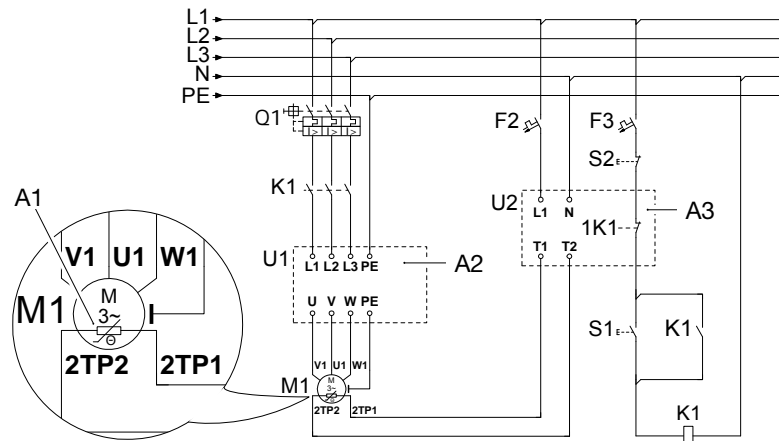

A1 PTC resistor
A2 Drive control

A3 PTC resistor and evaluation unit

Circuit diagram with PTC resistor evaluation via the drive control

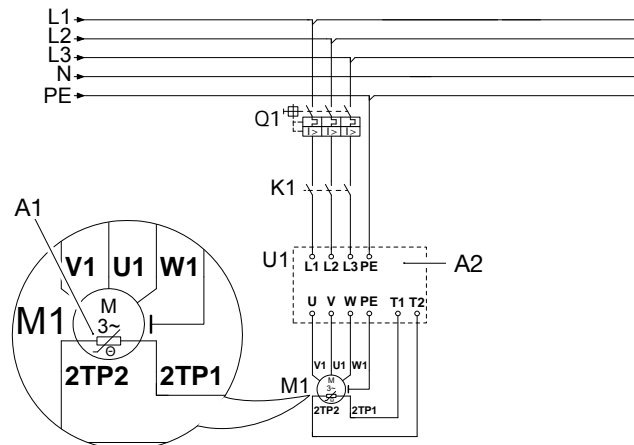

A1 PTC resistor

A2 Drive control

6.7 Connect auxiliary ventilator

This chapter is only valid for G-BH2 with auxiliary ventilator (item 42, Options [→ 14]).



⚠ DANGER

Lethal electric shock on the housing due to the air gap being too small!

! Air gaps between non-insulated, voltage active components and the earth must be at least **5.5 mm** [0.217 in] to one another (for a measured voltage of $U_N \leq 690$ V).

1. Avoid projecting cable ends.
2. Ensure electrical connections are durably resilient.



⚠ DANGER

Lethal electric shock due to arcing on the housing!

! The terminal box must be free of foreign objects, dirt and moisture.

- ① Seal terminal box lid and cable feed openings so that they are dust and water tight.

NOTICE

Destruction due to overheating!

For operation without the auxiliary ventilator running, the G-BH2 can overheat and be destroyed.

① Provide forced switching that prevents an operation of the G-BH2 without the auxiliary ventilator running.

1. Carefully remove blind plugs.
2. Insert screws.
3. Connect earth conductor to terminal.
4. Connect switch stirrup according to circuit diagram in the terminal box.
Note torque settings for terminal plate connections.
For connections with a terminal clip, route the conductor so that both pin ends are at approx. equal clip height.
Earth conductor and exterior earth conductor must be bent into a "U" shape.
All other conductors must be bent into a "U" shape or connected using a suitable terminal end.
5. Connect the auxiliary ventilator to a separate mains connection.

6.8 Parameterising the drive control

NOTICE

The G-BH2 fails due to an overload of the motor!

! G-BH2 are not ventilators! Operation with the setting "**Variable torque**" or "**Square characteristic**" is not permitted.

① Always operate G-BH2 with operating mode "**Constant torque**" or "**Linear characteristic**".

A clock frequency of 8 kHz is recommended. The minimum clock frequency is 4 KHz .

6.8.1 Parameterize integrated drive control 2FC4...-1ST/PB/CB/SC

The integrated drive control **2FC4...-1ST/PB/PN/SC/CB** is already parameterized on delivery. Brake and acceleration times must be adapted to the process. Other settings are not compulsory.

6.8.2 Parameterize integrated drive control 2FC4...-1NE

The integrated drive control **2FC4...-1NE** is already parameterized on delivery. Brake and acceleration times must be adapted to the process. Other settings are not compulsory.

6.8.3 Parameterize external drive control 2FC4...-1ST/PB/CB/SC

1. Parameterize external drive control **2FC4...-1ST/PB/PN/SC/CB** with motor data (rating plate [→ 12]), the drive control parameters [→ 46] and the related drive control operating instructions [→ 6].
2. Identify the motor.

6.8.4 Parameterize the external drive control 2FC4...-2

External drive control 2FC4...-2, adjust the parameters with the keypad

- ! Remove the keypad after an operating error and reconnect it. Reset the connection parameters.
- 1. Plug in the keypad and wait approx. 3 seconds.
 - ✓ The keypad carries out a self-test.
- 2. Set the values according to the table.

Code no.	Parameter designation	Type	Value	Important
C0010	minimum output frequency [Hz]	2BH20... with auxiliary ventilator	10	C0010 only limits the analogue input 1
		2BH20... with standard ventilator	25	
C0011	maximum output frequency [Hz]	all	see Parameter drive control 2FC4...-.NE [→ 46] or item N rating plate [→ 12]	
C0012	Run-up time main set value [s]	all	*	reference: Frequency change 0 Hz ... C0011
C0013	Elapsed time main set value [s]	all	*	reference: Frequency change C0011 ... 0 Hz
C0015	Nominal frequency inverter [Hz]	all	see Parameter drive control 2FC4...-.NE [→ 46] or rating plate [→ 12]	

* Dependent on the drive system, consisting of the motor and drive control. Adjust for use with suitable values.

6.8.5 Parameterize external drive control from third party

set the optimum process parameters within the limits defined in these instructions using the motor data (rating plate [→ 12]), the drive control parameters [→ 46] and the operating instructions of the drive control manufacturer [→ 6].

7.1 Measures after a long shut-down period

Replace ball bearings and radial shaft seal

! When the time at a standstill exceeds **4 years** since the last commissioning.

1. Replace the rolling bearing.
2. Clean adjacent bearing areas for open ball bearings and re-grease.
3. Replace and grease the radial shaft seal.

If the standstill conditions vary (Storage [→ 18]), a reduced ball bearing service life is to be expected.

Measuring the motor insulation resistance

- ① Measuring the motor insulation resistance.
 - ✓ Value >1 kΩ per volt of measured voltage: no measures necessary.
 - ✓ Value ≤1 kΩ per volt of measured voltage: Dry winding.

7.2 Tests during commissioning or re-commissioning

Prior to commissioning or re-commissioning of the G-BH2, test that

- Is the G-BH2 properly fitted and aligned?
- all pipes and hoses are correctly connected and sealed
- all fixing screws, connecting elements and electrical connections are fixed at the given tightening torques
- Do the operating conditions match the data plate details given above?
- Are the maximum speeds being monitored and adhered to through the control?
- Have all protection measures been completed?
- Cooling air supply not affected?
- Is the auxiliary ventilator ready for operation?

7.3 Check the direction of rotation

Test the direction of rotation of the compressor

1. Switch on the G-BH2 briefly and then switch it off again.
2. **⚠ WARNING! With incorrect electrical connection: Risk of injury due to drawing in and suction! Do not perform the overpressure test with your hands!**
Perform the overpressure test with a sheet of paper on the discharge side (item 5, Structure [→ 13]).
 - ✓ Overpressure present: direction of rotation is correct, no measures
 - ✓ Negative pressure present: Direction of rotation incorrect, change direction of rotation by interchanging two phases of electrical supply line

Test the direction of rotation of the auxiliary ventilator

- ! Only required for G-BH2 with auxiliary ventilator (item 42, Options [→ 14]).
1. Switch on the G-BH2 briefly and then switch it off again.
 2. Hold a sheet of paper in front of the air grille of the auxiliary ventilator (item 42.1, Structure [→ 13]).
 - ✓ The sheet is suctioned: direction of rotation is correct, no measures
 - ✓ The sheet is blown off: Direction of rotation incorrect, change direction of rotation by interchanging two phases of electrical supply line

7.4 Sensors function check

- ① Check the control for error messages by disconnecting the sensors (e.g. PTC resistor).
- ✓ Remedy the cause of the error for any malfunctions.

7.5 Measure the acoustic emissions

- ! It is necessary to measure the acoustic emissions for G-BH2 without piping or G-BH2 without silencers or G-BH2 with piping.
- 1. Ensure that all persons in the potentially excessive noise area of the G-BH2 wear ear protection.
- 2. Switch the G-BH2 on.
- 3. Measure sound during operation.
- 4. Switch the G-BH2 OFF.
- 5. If necessary, provide sound protection measures (e.g. additional silencers, ear protection, designation of noise areas).

7.6 Measure oscillations

It is recommended to carry out oscillation measurements for the prescribed operating speeds. If the permitted Speed of oscillation [→ 45] is exceeded, provide measures for Reduction of oscillations and noises [→ 20].

**! WARNING**

**Risk of burns due to temperatures of up to approx. 160°C [320°F]!
Contact with hot surfaces, pipes and hoses, can lead to burns.**

1. Do not touch surfaces provided with warning signs.
2. Allow to cool after removing from service

8.1 Switch on

1. If fitted, open the shut-off devices in the suction/pressure lines.
2. Switch the power supply and auxiliary ventilator (if necessary) on.
 - ✓ The G-BH2 begins to suction conveyed media.

8.2 Switch off

1. Switch the power supply and auxiliary ventilator (if necessary) off.
 - ✓ The G-BH2 interrupts the suction of the conveyed media. The pressure will be slowly reduced.
2. If fitted, close shut-off devices in suction and pressure lines.

8.3 Switch off in emergency

1. The G-BH2 can be switched off in emergency without any particular precautions.
 - ✓ If the brakes of the G-BH2 are actively employed, restarting in the opposite direction of rotation must be prevented.
2. Determine the cause.
3. Rectify the risk.
4. Put the G-BH2 back into operation.



⚠ DANGER

Lethal electric shock from G-BH2 with drive control!

The drive control continues to be live after the intermediate circuit voltage has been switched off and slowly becomes de-energised.

1. After switching off, wait for **at least 3 minutes**.
2. Before opening the drive control, ensure that it is de-energised.

⚠ WARNING

Danger of crushing and cutting as well as burns!

Work on the G-BH2 when it is running can lead to serious injuries. Contact with hot surfaces, pipes and hoses, can lead to burns.

1. Switch the G-BH2 off and disconnect it from the power supply.
2. Wait until the impeller stops.
3. Allow G-BH2 to cool down.
4. Use personal protective equipment.

Voiding of the warranty!

The opening of the G-BH2 by the operator within the warranty period can lead to voiding of the warranty.

Fault	Cause	Corrective measure	To be carried out by
G-BH2 does not run and does not make any noise.	Power supply failure of the G-BH2.	① Correct the break in fuses, terminals or power supply lines.	Electrician
	Drive control intermediate circuit voltage is too low.	① Check mains voltage and drive control.	Electrician
	Drive control locked.	① Use controller block.	Owner
	Incorrect setpoint source	① Change setpoint source.	Owner
	Target value of the drive control is "0".	① Specify target value.	Owner
G-BH2 does not start up and makes noises.	Failure in one of the power supply lines.	① Correct the break in fuses, terminals or power supply lines.	Electrician
	Impeller rubs or rotor is jammed.	① Open G-BH2, remove foreign objects, clean or replace parts.	Service*
	Impeller faulty.	① Replace impeller.	Service*
	Rolling bearing is faulty.	① Replace the rolling bearing.	Service*
G-BH2 turns unevenly.	Underexcitation or overexcitation of the drive control motor.	① Check motor data. Identify the motor, if necessary.	Owner
After release, the drive control switches into fault	Differential pressure does not correspond to the details on the data plate.	① Reduce differential pressure.	Owner
		① If necessary, clean filters, silencers and connecting pipes.	Service*
	Impeller rubs or rotor is jammed.	① Open G-BH2, remove foreign objects, clean or replace parts.	Service*

Fault	Cause	Corrective measure	To be carried out by
	Rolling bearing in motor or compressor part faulty.	① Replace the rolling bearing.	Service*
Circuit breaker triggered again after switching motor on or current draw too high	Motor overloaded. Settings deviate from details on rating plate.	① Reduce settings.	Qualified personnel
	Short-circuit in winding.	① Check windings.	Electrician
	Filters, silencer elements or connecting pipes/hoses clogged.	① Cleaning of filters, silencer elements and connecting pipes/hoses.	Service*
	Impeller rubs or rotor is jammed.	① Open G-BH2, remove foreign objects, clean or replace parts.	Service*
G-BH2 does not reach the required speed or shows no or too little differential pressure	Incorrect direction of rotation.	① Check the direction of rotation.	Electrician
	Incorrect target speed for drive control	① Correct the target speed.	Qualified personnel
	Fluctuating density of conveyed media.	① Take into account recalculation of pressure values. Consult the manufacturer.	Manufacturer
	Analogue input on drive control incorrectly configured.	① Match the setting to the adjacent analogue signal.	Owner
	Maximum output frequency on drive control too low.	① Increase maximum output frequency. Do not exceed the maximum speeds given on the data plate.	Owner
	Suction filter or in-line filter clogged	① Clean filter inserts and replace as necessary.	Qualified personnel
	Additional silencers blocked	① Clean additional silencers and replace as necessary.	Qualified personnel
	Leaks on the plant.	① Seal the unit.	Qualified personnel
	Silencer protective grid clogged.	① Remove foreign objects and clean the protective grid.	Qualified personnel
	Radial shaft seal faulty.	① Replace the radial shaft seal.	Service*
	Change to the blade profile due to soiling.	① Clean the impeller, check for wear and replace as necessary.	Service*
G-BH2 runs, drive control target values are "0"	Minimum output frequency <0 Hz set.	No error, as due to the minimum output frequency default, the G-BH2 always starts up with a frequency <0 Hz, see Maximum speeds [-> 43].	—
Abnormal flow noises	Flow rate too high.	① Clean the pipes. Use pipes with a larger diameter as necessary.	Qualified personnel
	Silencer inserts soiled.	① Clean the silencer inserts, check for wear and replace as necessary.	Service*

Fault	Cause	Corrective measure	To be carried out by
Abnormal running noises or oscillations	Spring elements faulty	① Replace spring elements.	Qualified personnel
	Rolling bearing in motor or compressor part faulty.	① Replace the rolling bearing.	Service*
Vibrations too high	Spring elements faulty	① Replace spring elements.	Qualified personnel
G-BH2 leaks	Screw connections loose on pressure or suction side or on compressor cover	① Tighten screws.	Owner
	Radial shaft seal faulty.	① Check the radial shaft seal and replace as necessary.	Service*
Other error messages on drive control.	See manufacturer's operating instructions for the drive control	① See manufacturer's operating instructions for the drive control	User/electrician

* Correction by qualified personnel for repair is possible when the repair manual is available.

10.1 Maintenance



⚠ DANGER

**Lethal electric shock from G-BH2 with drive control!
The drive control continues to be live after the intermediate circuit voltage has been switched off and slowly becomes de-energised.**

1. After switching off, wait for **at least 3 minutes**.
2. Before opening the drive control, ensure that it is de-energised.

⚠ WARNING

**Danger of crushing and cutting as well as burns!
Work on the G-BH2 when it is running can lead to serious injuries. Contact with hot surfaces, pipes and hoses, can lead to burns.**

1. Switch the G-BH2 off and disconnect it from the power supply.
2. Wait until the impeller stops.
3. Allow G-BH2 to cool down.
4. Use personal protective equipment.

To guarantee safe operation of the G-BH2, the following maintenance intervals are recommended. They are dependent on the operating conditions and must be adjusted by the user as necessary.

Maintenance interval	Maintenance measure	To be carried out by
Depending on the concentration of the particles of dirt in the ambient air (at least every 1000 h)	① Check the auxiliary ventilator or fan guard and cooling ribs of the motor for dirt and if necessary clean with compressed air.	Operating personnel
	① Check silencers, silencer inserts and protective grids (item 11, Structure [→ 13]) as well as, if necessary, the suction filter (item 50, Ancillaries [→ 14]) or in-line filter (item 51, Ancillaries [→ 14]) for dirt, and if necessary clean or replace.	Qualified personnel
annual	① Check the control for error messages by disconnecting the sensors (e.g. bimetal switch, PTC resistor). Remedy the cause of the error for any malfunctions.	Electrician
40,000 h or 4.5 years Exceptions 30,000 h or 3.5 years for 2BH20360-1...L and M, 2BH20540-1...M and N, 2BH20540-3...R 20,000 h or 2.5 years for 2BH20780-1...P and Q	1. Replace the rolling bearing. 2. Clean adjacent bearing areas for open ball bearings and re-grease. Grease: UNIREX N3 (ESSO), alternative grease as per DIN 51825-K3N. Do not mix types of grease! 3. Replace and grease the radial shaft seal. Grease: UNIREX N3 (ESSO), alternative grease as per DIN 51825-K3N. Do not mix types of grease! Maintenance intervals have been determined for the following ambient and operating conditions: <ul style="list-style-type: none"> ▪ Temperature of the assembly environment: +20°C [+68°F] ▪ Conveyed media temperature on the suction side: +40°C [+104°F] ▪ Conveyed media: air ▪ Maximum pressure difference according to the rating plate (item K Rating plate [→ 12]) ▪ Level assembly on the foot ▪ 3600 min⁻¹ (60 Hz) speed in continuous operation 	Service*

Maintenance interval	Maintenance measure	To be carried out by
	When installing a cover, service intervals will halve Different ambient and operating conditions increase (e.g. lack of continuous operation, lower pressure differences) or reduce (e.g. operation with drive control, long storage time) the values. Detailed statements are only possible when taking the actual ambient and operating conditions into consideration.	

* Maintenance and repair by qualified personnel is possible when the repair manual is available.

10.2 Repairs and complaints

Please consult the service department regarding repairs and complaints before sending them to the manufacturer.

- Gardner Denver Deutschland GmbH
 Industriestraße 26
 97616 Bad Neustadt
 Tel.: +49 9771 6888 2000
 Fax: +49 9771 6888 11 2000
 E-mail: er.service-nes@gardnerdenver.com
 Internet: www.gd-elmorietschle.com

10.3 Ordering spare parts

Spare parts order as per repair manual [→ 6].

11.1 Decommissioning



DANGER

Lethal electric shock from G-BH2 with drive control!

The drive control continues to be live after the intermediate circuit voltage has been switched off and slowly becomes de-energised.

1. After switching off, wait for **at least 3 minutes**.
2. Before opening the drive control, ensure that it is de-energised.

WARNING

Danger of crushing and cutting as well as burns!

Work on the G-BH2 when it is running can lead to serious injuries. Contact with hot surfaces, pipes and hoses, can lead to burns.

1. Switch the G-BH2 off and disconnect it from the power supply.
2. Wait until the impeller stops.
3. Allow G-BH2 to cool down.
4. Use personal protective equipment.

! The G-BH2 can remain in the unit or be dismantled for storage.

1. Disconnect the G-BH2 from the power supply.
2. Depressurise the pipes.
3. G-BH2 Store [→ 18] or disassemble (Disposal [→ 40]).

11.2 Disassembly

1. Disconnect the G-BH2 from all electrical connections.
2. Dismantle the piping and hoses.
3. Close connections that are open.
4. Loosen the G-BH2 from the installation surface.
5. G-BH2 store [→ 18] or dispose [→ 40].

11.3 Disposal

WARNING

Burns, chemical burns or poisoning!

Burns, chemical burns or poisoning due to contact with harmful substances remaining in the G-BH2.

- ① Decontaminate the G-BH2 as instructed by the manufacturer of the hazardous substances.

! When performing disposal, adhere to the following:

1. Dismantle the G-BH2.
2. Collect liquids and grease and dispose of them separately in accordance with the valid local regulations.
3. Dispose of components according to the valid local regulations or recycle them.

12.1 Mechanical data

12.1.1 Weight

Example: Mass 2BH20360-1... **J** = **49 kg** (108 lbs)

Type	[kg (lbs)]						
	J	K	L	M	N	P	Q
2BH20360-1...	49 (108)	54 (119)	66 (146)	78 (172)	—	—	—
2BH20360-2...	—	74 (163)	85 (188)	96 (212)	103 (227)	128 (282)	—
2BH20360-3...	—	—	88 (194)	99 (218)	107 (236)	131 (289)	143 (315)

Type	[kg (lbs)]						
	K	L	M	N	P	Q	R
2BH20540-1...	74 (163)	85 (188)	96 (212)	104 (229)	—	—	—
2BH20540-2...	—	—	126 (278)	134 (296)	160 (353)	172 (379)	—
2BH20540-3...	—	—	—	161 (355)	188 (415)	200 (441)	215 (474)

Type	[kg (lbs)]						
	M	N	P	Q	R	S	T
2BH20780-1...	124 (273)	132 (291)	154 (340)	165 (364)	—	—	—
2BH20780-2...	—	171 (377)	197 (434)	208 (459)	223 (492)	261 (576)	—
2BH20780-3...	—	—	236 (520)	249 (549)	264 (582)	300 (661)	300 (661)

For the G-BH2 with integrated 2FC4...-1ST/PB/PN/SC/CB, the mass increases by the following values.

Type	[kg]	[lbs]
2FC4152	4	8.8
2FC4222 2FC4302 2FC4402	5	11
2FC4552 2FC4752	9	20
2FC4113 2FC4153 2FC4183 2FC4223	21	47

12.1.2 Connection dimensions

Fittings dimensions - internal threads

The internal thread is arranged according to the order as an ISO 228-G pipe thread or as an American NPT pipe thread.

NPT threads can be recognised by a marking on the connection flange (Y).

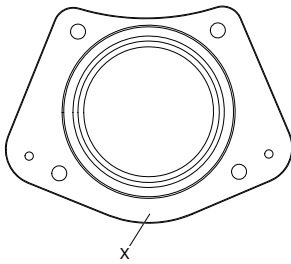

Type	Pipe thread ISO 228-G (X)	NPT threads (Y)
2BH20360	G 2½	NPT 2½ - 8
2BH20540	G 3	NPT 3 - 8
2BH20780	G 4	NPT 4 - 8

Fittings dimensions - hose connections

Hoses can be connected to all connection flanges.

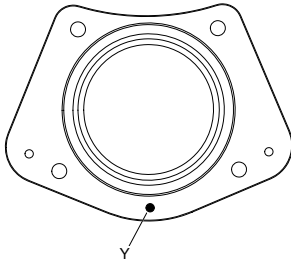

Type	Ø [mm]	Ø [in]
2BH20360	90	3.54
2BH20540	102	4.02
2BH20780	125	4.92

For further dimensions, see dimensional drawing.

12.1.3 Tightening torque values

The values apply if no other specifications are available.

Stainless steel screws

Mechanical properties A4-70 according to ISO 3506-1.

Thread	[Nm]	[ft lbs]
M5	2,3 – 2,7	1.70 – 2.70
M6	4,2 – 5,0	3.10 – 3.70
M8	7,5 – 9,0	5.55 – 6.65
M10	18 – 22	13.3 – 16.2
M12	35 – 42	25.8 – 31.0
M16	58 – 70	42.8 – 51.6

Steel screws

Tightening torques for non-electrical connections for nuts of strength class 8 and screws of strength class 8.8 according to ISO 898-1.

Thread	Non-electrical		Electrical*	
	[Nm]	[ft lbs]	[Nm]	[ft lbs]
M4	---	---	0,8 - 1,2	0.60 - 0.90
M5	4,5 - 5,5	3.32 - 4.06	1,8 - 2,5	1.35 - 1.85
M6	8,1 - 9,9	5.98 - 7.31	2,7 - 4,0	2.00 - 3.00
M8	21,6 - 26,4	15.9 - 19.5	---	---
M10	37,8 - 46,2	27.9 - 34.1	---	---
M12	63,0 - 77,0	46.5 - 56.8	---	---
M16	63,0 - 77,0	46.5 - 56.8	---	---

* applicable for terminal plate connections, except for terminal strips

Cable and wiring screw connections

Thread	Metal		Plastic	
	[Nm]	[ft lbs]	[Nm]	[ft lbs]
M12x1.5	4,0 – 6,0	2.95 – 4.42	2,0 – 3,0	1.48 – 2.21
M16x1.5	5,0 – 7,5	3.69 – 5.53	2,0 – 3,0	1.48 – 2.21
M25x1.5	6,0 – 9,0	4.42 – 6.64	2,0 – 3,0	1.48 – 2.21
M32x1.5	8,0 – 12	5.90 – 8.85	4,0 – 6,0	2.95 – 4.42
M40x1.5	8,0 – 12	5.90 – 8.85	4,0 – 6,0	2.95 – 4.42

Pipe thread according to ISO 228-1, EN 10226-1 and NPT thread

Type	[Nm]	[ft lbs]
G 2½ / NPT 2½-8	70 – 110	52 – 81
G 3 / NPT 3-8	80 – 130	59 – 96
G 4 / NPT 4-8	100 – 165	74 – 121

12.2 Permitted conditions for use

Any deviations from the following **permissible operating conditions** must be agreed with the manufacturer.

12.2.1 Installation height

The maximum installation height is **1000 m above sea level** (3280 ft above sea level) provided that no other installation height is specified on the rating plate under item N.

12.2.2 Maximum speeds
Mechanical speeds for operation without drive control

See item N Rating plate [→ 12]

Mechanical speeds for operation with drive control

Type	Minimum		Maximum
	[min ⁻¹]	[Hz]	[min ⁻¹]
2BH20... with auxiliary ventilator	600	10	See item N Rating plate [→ 12]
2BH20... with standard ventilator	2200	37	

12.2.3 Maximum temperatures

Different maximum temperatures are indicated on the rating plate under item N.

Maximum temperature of conveyed media

Minimum		Maximum	
°C	°F	°C	°F
-20	-4	+40	+104

Maximum ambient temperature

Minimum		Maximum	
°C	°F	°C	°F
-20	-4	+40	+104

12.2.4 Permissible pressure differences between the suction and pressure side in operation

Compressor operation [mbar]	Vacuum operation [mbar]
Item K ₂ , Rating plate [→ 12]	Item K ₁ , Rating plate [→ 12]

Loss of piping must be considered.

12.2.5 Pressure differences acting on the side-channel compressor

Maximum permissible pressure differences between the suction or pressure side and assembly environment in operation

Application example:

- Pressure of assembly environment ≠ atmospheric pressure
- Mixed operation

Compressor operation [mbar]	Vacuum operation [mbar]
Item K ₂ , Rating plate [→ 12]	Item K ₁ , Rating plate [→ 12]

Maximum permissible pressure differences between the suction or pressure side and assembly environment at a standstill

Application example:

- static leak test

1. A long-term, **constant pressure load** can lead to the ball bearing becoming degreased.
2. A long-term, **changing pressure load** at a standstill is not permitted.

Pressure difference overpressure [mbar]	Pressure difference vacuum [mbar]
Item K ₂ , Rating plate [→ 12]	Item K ₁ , Rating plate [→ 12]

12.2.6 Relative humidity

Ambient relative humidity

Maximum **60%** at **+40°C** (+104°F)

Relative humidity of conveyed media

Condensate formation is not permitted in the G-BH2.

12.2.7 Minimum distances for heat dissipation

Adhere to the following minimum distances for heat dissipation:

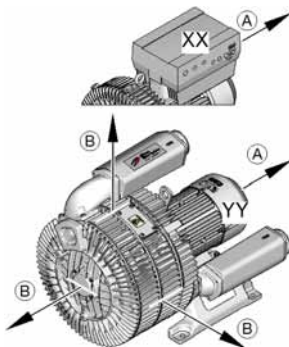

Type	[mm]			[in]		
	A (XX)	A (YY)	B	A (XX)	(YY)	B
2BH20...	100	55	40	3.95	2.17	1.57

12.2.8 Speed of oscillation

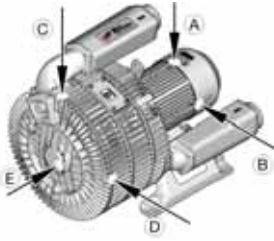

Maximum permissible oscillation speed for the constructed machine

Installation	[mm/s]	[in/s]
Rigid (e.g., foundation)	2.8	0,110
Elastic (e.g., spring elements)	4.5	0,177

The oscillation speed must be determined at the following measuring points

- on the motor side
 - vertically (fan guard/auxiliary ventilator screw connection - A)
 - horizontally (fan guard/auxiliary ventilator screw connection - B)
- on the compressor part
 - vertically (compressor cover - C)
 - horizontally (compressor cover - D)
 - axially (compressor cover next to the Elmo Rietschle logo - E)

12.3 Electrical data

Any deviations from the following **electrical data** must be agreed with the manufacturer.

The electrical data are provided on the Rating plate [→ 12].

12.3.1 Increased operating cycle frequency

The G-BH2 is designed for continuous operation. Consultation with the manufacturer is necessary for increased operating cycle frequency.

12.3.2 Parameter drive control 2FC4...-1ST/PB/PN/SC/CB

Example: 2BH20540-1 . . P.6 with Δ -switching and 400 V mains voltage = 5000 min⁻¹ maximum speed with drive control setting C0011 = 86

Voltage version	Switching	Mains voltage [V]	n max [min ⁻¹]	max. output frequency [Hz]
Code no. for 2FC4...- 1ST/PB/PN/SC/CB:				1,021
P.1	Y	400	3600	60
	Δ	400	5000	87
P.6	Y	400	3000	50
	Δ	400	5000	84
2.1	Y	400	Not permitted	
	Δ	400	5000	87
2.2	Y	400	3600	60
	Δ	400	Not permitted	
2.6	Y	400	Not permitted	
	Δ	400	5000	84

12.3.3 Parameter drive control 2FC4...-.NE

Example: 2BH20360-1 . . P.1 with Y-switching and 400 V mains voltage = 3,600 min⁻¹ maximum speed with drive control setting C0011 = 60 and C0015 = 58

Voltage version	Switching	Mains voltage [V]	n max [min ⁻¹]	max. output frequency [Hz]	U/f nominal frequency [Hz]
Code No. for 2FC....-1 and 2:				C0011	C0015
P.1	Y	400	3600	60	58
	Δ	400	6000	100	100
P.6	Y	400	3000	50	50
	Δ	400	5000	86	87
N.1	Y	400	Not permitted		
	Δ	400	6000	100	100
N.2	Y	400	3600	60	58
	Δ	400	Not permitted		
N.6	Y	400	Not permitted		
	Δ	400	5000	86	87

12.4 Pressure differences generated by the side-channel compressor

Maximum pressure differences generated in operation

Compressor operation [mbar]	Vacuum operation [mbar]
Item K ₂ , Rating plate [→ 12]	Item K ₁ , Rating plate [→ 12]

The pressure differences given on the rating plate have a tolerance of $\pm 10\%$ and apply to the permissible operating conditions [→ 43] and to the conveyed media of air.

12.5 Acoustic emissions

Noise level emissions L_{pA} according to noise test code ISO 2151 with reference to basic standard ISO 3744. Measured at a distance of 1 m for 70% Δp_{max} and connected supply lines, tolerance ± 3 dB(A).

Type	50 Hz [dB(A)]	60 Hz [dB(A)]
2BH20360-1....	70	70
2BH20360-2....	70	72
2BH20360-3....	70	73
2BH20540-1....	70	73
2BH20540-2....	70	74
2BH20540-3....	71	77
2BH20780-1....	71	75
2BH20780-2....	73	77
2BH20780-3....	74	78



www.gd-elmorietschle.de
er.de@gardnerdenver.com

Gardner Denver
Deutschland GmbH
Industriestraße 26
97616 Bad Neustadt · Deutschland
Tel. +49 9771 6888-0
Fax +49 9771 6888-4000

Gardner
Denver

Elmo Rietschle is a brand of
Gardner Denver's Industrial Products
Group and part of Blower Operations.