

Operating Instructions G-BH7e

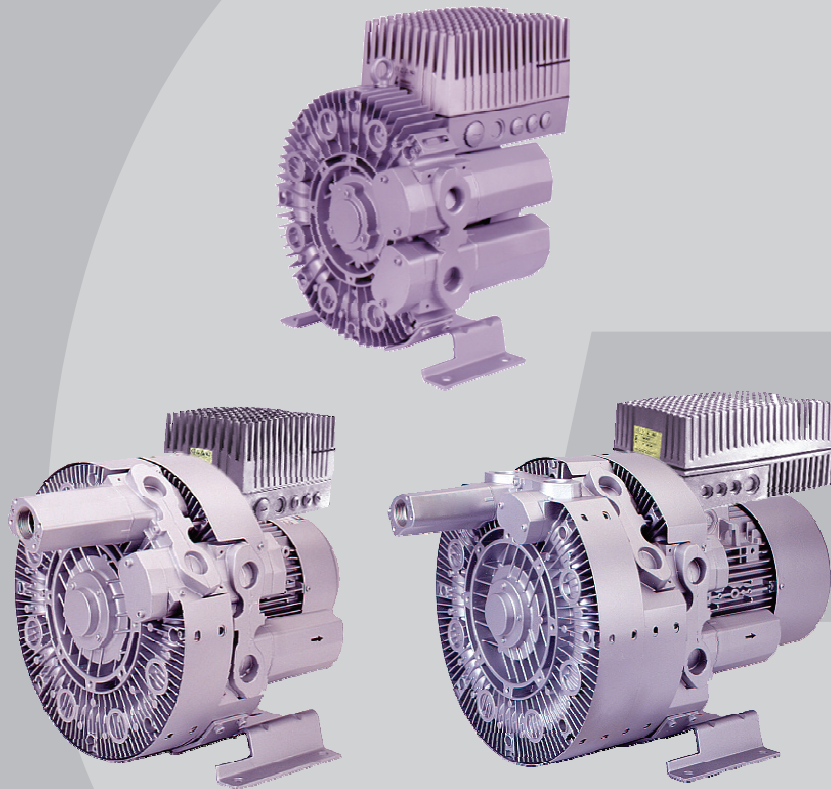

CE



**2BH72...N
2BH73...N
2BH74...N
2BH75...N
2BH76...N**



**G-Serie
G-Series**

**Seitenkanal
Side Channel**



Design of side channel blowers in conjunction with frequency inverters	3
Quick start guide	4
1 Safety instructions	5
1.1 Definitions	5
1.1.1 Safety alert symbols and signal words	5
1.1.2 Signal words	5
1.1.3 Abbreviations used	5
1.2 General safety and application notes	5
1.3 Residual risks	7
1.4 Application as directed	9
1.5 Foreseeable Misuse	10
2 Technical data	11
2.1 Mechanical data	11
2.1.1 Weights	11
2.1.2 Noise level	11
2.1.3 Temperature increase	12
2.2 Electrical data	12
2.3 General data/operating conditions	13
3 Transport and handling	14
3.1 Transport devices	14
3.2 Transport types	14
4 Installation	16
4.1 Installation	17
4.1.1 Important notes	17
4.1.2 Free spaces	18
4.1.3 Mounting	19
4.1.4 Final works	20
4.2 Mounting of the muffler	20
4.3 Connecting the pump-motor unit to the system	20
4.3.1 Important notes	20
4.3.2 Connecting the inlet line	21
4.3.3 Connecting the pressure line	21
4.4 Electrical installation	22
4.4.1 Important notes	22
4.4.2 Preparing works	23
4.4.3 Connecting frequency inverters 2FC4152-1NE00 and 2FC4222-1NE00	23
4.4.4 Connecting frequency inverters 2FC4302-1NE00 ... 2FC4752-1NE00	26
4.4.5 Wiring of control connections	29
4.4.6 Final works	32
5 Commissioning	34
5.1 Preparation	34
5.2 Parameter setting	35
5.2.1 The hand-held keypad 2FX4506-0NE00	35
5.2.2 Code table	37
5.3 Start-up of the pump-motor unit	39
5.4 Shut-down of the pump-motor unit	40
6 Operation	41
7 Shut-down and longer standstills	42
7.1 Preparation	42
7.2 Storage conditions	42

8	8.1	8.1.1	8.1.2	8.1.3	8.1.4	8.2	8.3	9		
8	8.1	8.1.1	8.1.2	8.1.3	8.1.4	8.2	8.3	9	Declaration of conformity	Form for statement on safety
43	43	43	44	45	47	47	48	49	50	51
Repair/ troubleshooting	Malfunfunctions at side channel blower	Frequency inverter status indications	Fault indication at the keypad	Fault indication reset (TRIP-RESET)	Service/ after-sales service	Decontamination and declaration of clearance	Disposal	Declaration of conformity	Form for statement on safety	

Design of side channel blowers in conjunction with frequency inverters

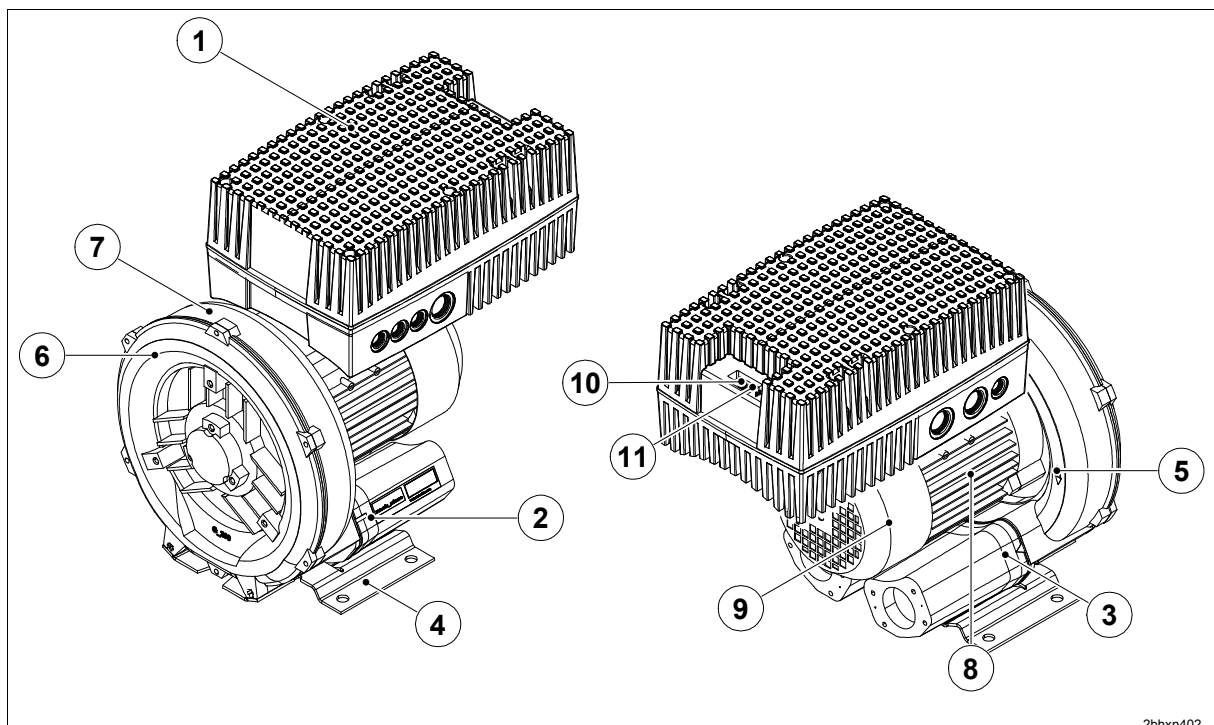

2btxn402

Position	Description	
1	Frequency inverter	
2	Inlet connection with muffler and arrow indicating delivery direction	
3	Discharge connection with muffler and arrow indicating delivery direction	
4	Base	
5	Arrow indicating direction of rotation	
6	Blower cover	
7	blower housing	
8	Drive motor	
9	Fan guard above the motor fan with rating plate, warning notices and arrow indicating direction of rotation	
10	Status display with 2 light-emitting diodes (red, green)	44
11	Communication interface for connecting the hand-held keypad	35

Fig. 1: Design of side channel blowers in conjunction with frequency inverters

Quick start guide

Side channel blowers are pre-configured for four operating modes. It only takes a few steps and they are ready for operation:

ACHTUNG

- The drive motor is protected against overheating by a thermal detector.
 - If the drive motor gets too hot, the frequency inverter will switch off the pump-motor unit.
 - Please contact the manufacturer if the hydraulic process does not allow immediate switch-off.
- A minimum wiring is required for commissioning! (📖 22)

1 Read the safety instructions.

📖 The safety instructions start on page 5.

2 Install the pump-motor unit and attach it.

📖 Listing of the mounting steps starts on page 16.

3 Wire the pump-motor unit.

- Please observe that a minimum wiring is required!
 - Otherwise commissioning of the pump-motor unit is not possible.
- 📖 Important notes concerning the wiring start on page 22.

4 Put the pump-motor unit into operation.

📖 Description of the commissioning steps starts on page 34.

5 Adapt important process parameters.

- Adapt acceleration and deceleration time to the hydraulic process via C0012 and C0013.
- 📖 Description of parameter changing starts on page 35.

6 Adjust the speed.

A) Speed adjustment using a potentiometer

- The speed is adjusted via the analog input.
- The speed can be adjusted between a minimum and a maximum value. Description of potentiometer wiring starts on page 30.

B) Operation with several adjustable fixed speeds

- The speed of the pump-motor unit can be adjusted in steps of 1000/min via the digital inputs E3 and E4.
- 📖 Description of the wiring of E3 and E4 starts on page 30.

C) Operation with one fixed speed

- Connect hand-held keypad.
 - Set required fixed speed under C0140.
 - Disconnect hand-held keypad.
 - The pump-motor unit will be operated with this speed when switched on.
- 📖 Description of hand-held keypad connection and parameter changing starts on page 35.

D) Speed adjustment using the keypad

- Connect hand-held keypad.
 - Select C0140.
 - Set the required speed during the process using the keys ▲ _..
 - The pump-motor unit will be operated with the last set speed when switched on.
- 📖 Description of hand-held keypad connection and parameter changing starts on page 35.

1 Safety instructions

1.1 Definitions

To point out dangers and important information, the following signal words and symbols are used in these Operating Instructions:

1.1.1 Safety alert symbols and signal words

The safety alert symbol  is located in the safety instructions in the highlighted heading field on the left next to the signal word (DANGER, WARNING, CAUTION).

Safety instructions with a safety alert symbol indicate a danger of injuries.

Be sure to follow these safety instructions to protect against injuries or death!

Safety instructions without a safety alert symbol indicate a danger of damage. – Be sure to follow these safety instructions to avoid material damage!

1.1.2 Signal words

<i>DANGER</i>	The signal words are located in the safety precautions in the highlighted heading field.
<i>WARNING</i>	
<i>CAUTION</i>	They follow a certain hierarchy and indicate (in conjunction with the safety alert symbol, see Chapter 1) the seriousness of the danger and the type of warning .
<i>NOTICE</i>	
<i>NOTE</i>	

See the following explanations:

 DANGER
<p>Danger of injuries. Indicates an imminently hazardous situation, that will result in death or serious injury if the corresponding measures are not taken.</p>

 WARNING
<p>Danger of injuries. Indicates a potentially hazardous situation, that could result in death or serious injury if the corresponding measures are not taken.</p>

 CAUTION
<p>Danger of injuries. Indicates a potentially hazardous situation, that may result in minor or moderate injury if the corresponding measures are not taken.</p>

CAUTION
<p>Danger of damage. Indicates a potentially hazardous situation that may result in property damage if the corresponding measures are not taken.</p>

NOTICE
<p>Indicates a possible disadvantage, i.e. undesirable conditions or consequences can occur if the corresponding measures are not taken.</p>

NOTE
<p>Indicates a possible advantage if the corresponding measures are taken; tip.</p>

1.1.3 Abbreviations used

Product designation

For side channel blower in conjunction with frequency inverters the term pump-motor unit is used in these Instructions.

Cross-reference

Cross-references to other parts of these Instructions are marked with a book symbol:  9)

1.2 General safety and application notes

 WARNING
<p>Improper use of the pump-motor unit can result in serious or even fatal injuries! These Operating Instructions</p> <ul style="list-style-type: none"> • must have been read completely and understood before beginning any work with or at the pump-motor unit, • must be strictly observed, • must be available at the operating location of the pump-motor unit.

⚠ WARNING

Improper use of the pump–motor unit can result in serious or even fatal injuries!

Only operate the pump–motor unit

- for the purposes indicated under "Application as directed"!
- with the media indicated under "Application as directed"!
- with the values indicated under "Technical data"!

⚠ WARNING

Improper use of the pump–motor unit can result in serious or even fatal injuries!

All work on and with the pump–motor unit (transport, installation, operation, shut–down, maintenance, disposal) may only be carried out by trained, reliable expert personnel!

⚠ WARNING

When working on the pump–motor unit, there is a danger of injury, e.g. in the form of cuts/cutting off, crushing and burns!

During all work on and with the pump–motor unit (transport, installation, operation, shut–down, maintenance, disposal) wear personal safety equipment (safety helmet, safety gloves, safety shoes)!

⚠ WARNING

Hair and clothing can be pulled into the pump–motor unit or caught and wound up by moving parts! Do not wear long, loose hair or wide, loose clothing! Use a hairnet!

⚠ DANGER!

Electrical danger!

Work on electrical installations may be carried out by trained and authorized electricians only!

⚠ DANGER!

Electrical danger!

Before beginning work on the pump–motor unit or system, the following measures must be carried out :

- Deenergize.
- Secure against being switched on again.
- Determine whether deenergized.
- Ground and short–circuit.
- Cover or block off adjacent energized parts.

⚠ DANGER!

Electrical danger!

Do not open the frequency inverter until absence of electricity has been ensured!

⚠ WARNING

Danger due to vacuum and gauge pressure: sudden escape of media (skin and eye injuries), sudden drawing–in of hair and clothing!

Danger due to escaping media: burns!

Use mounting elements, connections, lines, fittings and containers with sufficient freedom from leaks and strength for the pressures which occur.

Check the mounting elements, connections, lines, fittings and containers for strength, leaks and firm seating at regular intervals!

⚠ WARNING

Danger from rotating parts (motor fan, impeller, shaft): cutting/cutting off of extremities, grasping/winding up of hair and clothing!

Danger due to vacuum and gauge pressure: sudden escape of media (skin and eye injuries), sudden drawing–in of hair and clothing!

Danger due to escaping media: burns!

Commissioning and operation only under the following conditions:

- The pump–motor unit must be completely assembled. When doing so, pay particular attention to the following components:
 - the blower cover,
 - the mufflers on inlet and discharge connections,
 - the fan guard.
- The pipes and hoses must be connected to inlet and discharge connections.
- Inlet and discharge connections and the connected pipes/hoses may not be closed, clogged or soiled.
- Check the mounting elements, connections of the pipe/hose connections, lines, fittings and containers for strength, leaks and firm seating at regular intervals.

⚠ WARNING

Danger from rotating parts (motor fan, impeller, shaft): cutting/cutting off of extremities, grasping/winding up of hair and clothing!

Danger due to vacuum and gauge pressure: sudden escape of media (skin and eye injuries), sudden drawing-in of hair and clothing!

Danger due to escaping media: burns!

Before beginning work on the pump-motor unit, take the following measures :

- Shut down pump-motor unit and secure against being switched on again.
- Attach a sign on the system controller and on the control elements for the pump-motor unit: "DANGER! Maintenance work on the vacuum pump/compressor! Do not switch on!"
- Wait for pump-motor unit to come to a complete stop.
 - Observe run-on time!
- Allow pump-motor unit to cool!
- Shut-off lines.
 - Release pressure.
- Make sure that no vacuum or gauge pressure is present in the lines/tanks to be opened.
- Make sure that no media can escape.

⚠ WARNING

Danger from rotating impeller: cutting/cutting off of extremities!

The rotating impeller is accessible with the inlet and discharge connections open!

Do not reach into the pump-motor unit through open connections!

Do not insert objects into the pump-motor unit through the openings!

⚠ WARNING

Danger from rotating impeller: cutting/cutting off of extremities!

The rotating impeller is accessible with the inlet and discharge connections open!

With free entry and exit of gases, i.e. with direct intake out of or direct feeding into the atmosphere without piping, the following therefore applies:

- Provide the inlet and discharge connections of the pump-motor unit either with additional mufflers or with additional piping of a sufficient length to prevent access to the impeller!

⚠ WARNING

Danger of burns from hot surface of the pump-motor unit and from hot media!

High temperatures of up to approx. 160 °C [320 °F] can occur on the surface of the pump-motor unit:

- Cover the pump-motor unit with a suitable touch protection (e.g. perforated plate cover or wire cover).
- Do not touch during operation!
- Allow to cool after shut-down!

1.3 Residual risks

⚠ WARNING

Danger zone:
Hot surface of up to approx. 160 °C [320 °F].

Hazard:
Possible burns.

Protective measures:
Cover the pump-motor unit with a suitable touch protection (e.g. perforated plate cover or wire cover).

⚠ WARNING

Danger zone:
Fan guard

Hazard:
Long, loose hair can be drawn into motor fan through the fan guard grate, even with fan guard mounted!

Protective measures:
Wear hair net!

 **WARNING**

Danger zone:
Missing or defective muffler on inlet or discharge connection.

Hazard:
Possible serious hearing damage due to emitted noise.

Protective measures:
Have missing or defective mufflers replaced.
Conduct a noise measurement in the system after installing the pump-motor unit.
The following measures must be taken by the operator:

- from 85 dB(A):
 - Hearing protection must be available.
- from 90 dB(A):
 - Mark noise area with a warning sign.
 - Wear hearing protection.

 **WARNING**

Danger zone:
Environment of pump-motor unit.

Hazard:
Possible serious hearing damage due to emitted noise.

Protective measures:
Conduct a noise measurement in the system during operation after installing the pump-motor unit.
The following measures must be taken by the operator:

- from 85 dB(A):
 - Hearing protection must be available.
- from 90 dB(A):
 - Mark noise area with a warning sign.
 - Wear hearing protection.
 - With free entry and exit of gases, i.e. with direct intake out of or direct feeding into the atmosphere without piping, attach an additional muffler.

CAUTION

Danger zone:
Frequency inverter

Hazard:
Material damage at the frequency inverter caused by switching on the device too frequently with too short intervals.

Protective measures:
In the case of cyclic mains switching for a longer time period, allow at least 3 minutes between two switch-on actions.

CAUTION

Danger zone:
Side channel blower

Hazard:
Material damage at the side channel blower caused by too high speeds.

Protective measures:

- Do not set the output frequency at the frequency inverter higher than the maximum frequency specified in the documentation.
- Use special overspeed monitors if necessary.

1.4 Application as directed

Validity of the Operating Instructions

These Operating Instructions are valid for G-BH7e series side channel blower in conjunction with frequency inverters equipped with the following frequency inverters:

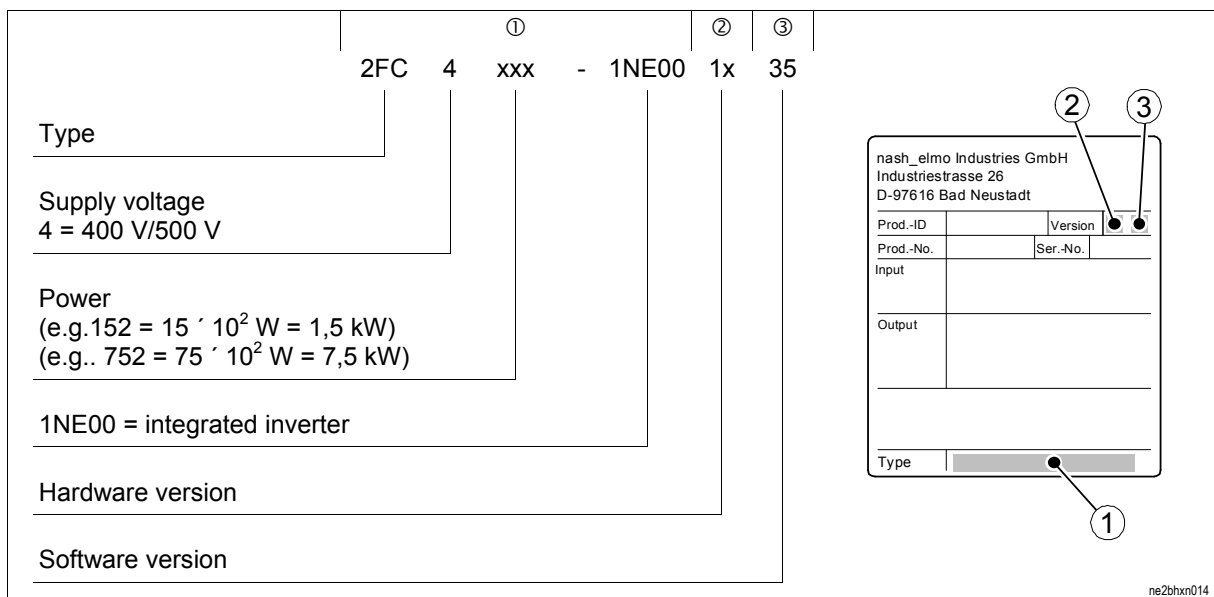

Fig. 2: Typschild

These Operating Instructions

- contain instructions bearing on transport and handling, installation, commissioning, operation, shut-down, storage, servicing and disposal,
- must be completely read and understood by all operating and servicing personnel before beginning to work,
- must be strictly observed,
- must be available at the site of operation in a complete and perfectly legible condition.

Operating and servicing personnel

- These persons must be trained and authorized for the work to be carried out.
- Work on electrical installations may be carried out by trained and authorized electricians only.

G-BH1e series side channel blower in conjunction with frequency inverters

- are pump-motor units for generating vacuum or gauge pressure.
- are used to extract, pump and compress the following gases:
 - Air,
 - Non-flammable, non-aggressive, non-toxic and non-explosive gases or gas-air mixtures.

- With differing gases/gas-air mixtures, inquire with the manufacturer.
- are intended for industrial applications.
- are designed for continuous operation:
 - With increased switch-on frequency (at equal intervals of approx. 5 times per hour) or increased gas entry temperature and ambient temperature, the limit overtemperature of the winding and the bearings can be exceeded.
 - Consultation with the manufacturer is required for operating conditions of this kind.
- are equipped with a three-phase drive motor with mounted frequency inverter.
- are available in the following models:
 - single-impeller (single-stage)
 - two-impeller (two-stage)
 - three-impeller (three-stage)

Higher pressure differences can be achieved with the two-impeller and three-impeller pump-motor units.

- are primarily intended for higher pressure conditions;

During operation the limit values listed under "Technical data" must always be complied with. (11)

1.5 Foreseeable Misuse

It is prohibited

- to use the pump-motor units in applications other than industrial applications unless the necessary protection is provided on the system, e.g. touch guards suitable for children's fingers,
- to use the pump-motor units in rooms in which explosive gases can occur,
- to extract, deliver and compress explosive, flammable, corrosive or toxic media,
- to operate the pump-motor units with values other than those specified in the chapter "Technical data".

Any unauthorized modifications of the pump-motor units are prohibited for safety reasons.

The operator is only permitted to perform the maintenance and service work described in these Operating Instructions.

Any maintenance and service work which goes beyond this may only be performed by companies authorized by the manufacturer (inquire with the manufacturer).

2 Technical data

2.1 Mechanical data

2.1.1 Weights

Type	Weight	
	approx. [kg]	approx. [lbs]
Single-impeller design		
2BH7210-0.N1	20	44
2BH7210-0.N5	32	71
2BH7310-0.N2	20	44
2BH7310-0.N6	35	77
2BH7410-0.N1	27	60
2BH7410-0.N5	42	93
2BH7510-0.N2	39	86
2BH7510-0.N6	48	106
2BH7610-0.N3	45	99
Two-impeller design		
2BH7220-0.N5	38	84
2BH7320-0.N5	40	88
2BH7320-0.N8	46	101
2BH7420-0.N2	43	95
2BH7420-0.N5	49	108
2BH7520-0.N7	61	134
2BH7620-0.N3	58	128
2BH7620-0.N4	68	150
Three-impeller design		
2BH7630-0.N6	96	212

2.1.2 Noise level

Measurement conditions

Measuring-surface sound-pressure level as per EN ISO 3744, measured at a distance of 1 m [3.28 ft] at an operating point of approximately 2/3 of the permissible total pressure difference with the lines connected without a vacuum or pressure relief valve, tolerance ± 3 dB (A).

Type	1-m measuring-surface sound-pressure level L for operation with output frequency [dB(A)]		
	50 Hz	60 Hz	86 Hz
Single-impeller design			
2BH7210-0.N1	70	70	74
2BH7210-0.N5	70	70	74
2BH7310-0.N2	70	70	76
2BH7310-0.N6	70	70	76
2BH7410-0.N1	70	70	76
2BH7410-0.N5	70	70	76
2BH7510-0.N2	70	70	78
2BH7510-0.N6	70	70	78
2BH7610-0.N3	70	71	77
Two-impeller design			
2BH7220-0.N5	70	70	74
2BH7320-0.N5	70	70	76
2BH7320-0.N8	70	70	76
2BH7420-0.N2	70	70	76
2BH7420-0.N5	70	70	76
2BH7520-0.N7	70	70	78
2BH7620-0.N3	70	71	80
2BH7620-0.N4	70	71	80
Three-impeller design			
2BH7630-0.N6	77	80	80

2.1.3 Temperature increase

The information listed in the following tables corresponds to the heating of the side channel housing and the air exiting compared to the ambient temperature during operation with a permissible total pressure difference and an air pressure of 1013 mbar [14.7 psi]. At lower air pressures these values increase.

Type	Temperature increase for operation with output frequency (approx.)							
	50 Hz		60 Hz		86 Hz			
	ΔT [K]	Δv [F]	ΔT [K]	Δv [F]	ΔT [K]	Δv [F]		
Single-impeller design								
2BH7210-0.N1	52	126	61	142	≤ 120	≤ 248		
2BH7210-0.N5	52	126	77	171				
2BH7310-0.N2	81	178	86	187				
2BH7310-0.N6	88	190	112	234				
2BH7410-0.N1	90	194	101	214				
2BH7410-0.N5	114	237	120	248				
2BH7510-0.N2	120	248	112	243				
2BH7510-0.N6	120	248	120	248				
2BH7610-0.N3	118	244	124	255				
Two-impeller design								
2BH7220-0.N5	55	131	86	186	≤ 120	≤ 248		
2BH7320-0.N5	81	178	124	255				
2BH7320-0.N8	120	248	120	248				
2BH7420-0.N2	89	192	80	176				
2BH7420-0.N5	121	250	117	243				
2BH7520-0.N7	125	257	110	230				
2BH7620-0.N3	124	255	126	259				
2BH7620-0.N4	124	255	126	259				
Three-impeller design								
2BH7630-0.N6	120	248	120	248			≤ 120	≤ 248

Tightening torques for screw connections

The following values apply if no other data are given. With non-electrical connections, property classes of 8.8 and 8 or higher as per DIN ISO 898 (DIN EN 20898 / DIN ISO 898) are assumed.

 Tightening torques for non-electrical connections		
Thread	[Nm]	[lb-in]
M4	2,7 ... 3,3	23,9 ... 29,2
M5	3,6 ... 4,4	31,9 ... 38,9
M6	7,2 ... 8,8	63,7 ... 77,9
M8	21,6 ... 26,4	191 ... 234
M10	37,8 ... 46,2	335 ... 409
M12	63,0 ... 77,0	558 ... 681

 Tightening torques for cable and conduit glands Metal		
Thread	[Nm]	[lb-in]
M12x1,5	4,0 ... 6,0	35,4 ... 53,1
M16x1,5	5,0 ... 7,5	44,3 ... 66,4
M20x1,5	6,0 ... 9,0	53,1 ... 79,7
M32x1,5	8,0 ... 12,0	70,8 ... 106
M40x1,5		

 Tightening torques for cable and conduit glands Plastic		
Thread	[Nm]	[lb-in]
M12x1,5	2,0 ... 3,5	17,7 ... 31,0
M16x1,5	3,0 ... 4,0	26,6 ... 35,4
M20x1,5	4,0 ... 5,0	35,4 ... 44,3
M32x1,5	5,0 ... 7,0	44,3 ... 62,0
M40x1,5		

2.2 Electrical data

See rating plate.

2.3 General data/operating conditions

Conformity				
		CE	Low-Voltage Directive	
Vibration resistance				
		Acceleration resistant up to 2g (Germanischer Lloyd, general conditions)		
Vibration velocity				
	max. v_{eff}	4 mm/s	[0,013 ft/s]	Depending on the application case and the system type it may be necessary to use vibration dampers.
Site altitude				
	min.	0 m üNN	[0 ft amsl]	
	max.	1000 m üNN	[3280 ft amsl]	For installations above 1000 m amslA [3280 ft amsl] consultation of the manufacturer is required.
Climatic conditions				
		Class 3K3 to EN 50178 (without condensation, relative humidity 30 ... 95 %)		
Ambient temperatures				
Transport	min.	-25°C	[-13°F]	
	max.	+70°C	[+158°F]	
Storage	min.	-25°C	[-13°F]	
	max.	+60°C	[+140°F]	
Operation	min.	-20°C	[-4°F]	Between +25 °C [+77 °F] and +40 °C [+104 °F] reduce the total pressure difference indicated on the rating plate by 0.7 %/°C [0.4 %/°F]. Operation at higher temperatures may damage the winding and shorten the grease change interval.
	max.	+40°C	[+104°F]	
	rated value	+25°C	[+77°F]	
Temperature of pumped gases				
	max.	+40°C	[+104°F]	Pump-motor units for higher media temperatures Pump on request.
	rated value	+15°C	[+59°F]	
Pressures				
Inlet pressure	min.	See rating plate		
Discharge pressure during compressor operation	max.	See rating plate		
Permissible total pressure difference	max.	See rating plate		The total pressure difference specified on the rating plate only applies under the following conditions: <ul style="list-style-type: none"> • Ambient temperature: 25 °C [77 °F] • Temperature of the pumped gas at the inlet connection: 15 °C [59 °F] • Pressure: <ul style="list-style-type: none"> – for vacuum-pump operation: 1013 mbar [14.7 psia] at the discharge connection – for compressor operation: 1013 mbar [14.7 psia] at the inlet connection
zulässiger Druck im Aggregat	max.	2 bar abs.	[29 psia]	At this pressure the operation of the pump-motor unit may be considerably impaired. Provide a corresponding protective device (e.g. pressure relief valve) if necessary.

3 Transport and handling

⚠ WARNING

Tipping or falling can lead to crushing, broken bones etc.!

Sharp edges can cause cuts!

- Wear personal safety equipment (safety gloves, safety shoes and safety helmet) during transport!

⚠ WARNING

Danger from lifting heavy loads!

Manual handling of the pump-motor unit is only permitted within the following limits:

- max. 30 kg [max. 66 lbs] for men
- max. 10 kg [max. 22 lbs] for women
- max. 5 kg [max. 11 lbs] for pregnant women

For weights above the given values use suitable lifting appliances and handling equipment!

Weight of the pump-motor units: (📖 11)

⚠ WARNING

Danger from tipping or falling loads!

- Prior to transport and handling make sure that all components are securely assembled and secure or remove all components the fasteners of which have been loosened!
- When transporting with lifting equipment, observe the following basic rules:
 - The lifting capacity of lifting equipment and lifting gear must be at least equal to the unit's weight. For the weight of the pump-motor units see: (📖 11)
 - The pump-motor unit must be secured so that it cannot tip or fall.
 - Do not stand or walk under suspended loads!

3.1 Transport devices

All pump-motor units with a weight of more than 30 kg are equipped with an eye bolt at the side channel housing.

The crane hook can be hooked directly into the eye bolt.

Alternatively the pump-motor units can be transported with lifting belts.

⚠ WARNING

Danger from tipping or falling loads!

- Place the lifting belts under the side channel housing and under the motor.
- Attach the lifting belts in such a way that the suspending pump-motor unit is balanced and cannot slip out of the lifting belts.

3.2 Transport types

CAUTION

Pump-motor unit damage caused by improper manual handling!

- Do not carry the pump-motor unit by holding it at the frequency inverter!
- Avoid heavy impact loads during transport.

CAUTION

Pump-motor unit damage caused by improper transport with lifting appliances!

- Do not attach the lifting appliances to the frequency inverter!
- The eye bolt at the side channel housing must
 - be screwed tightly.
 - be exactly in axial direction of the pump-motor unit. Lay shims under the eye bolt if necessary.
- Loads laterally to the ring level are not permissible.
- Avoid heavy impact loads during transport.

Type	Type of transport	
	manually	with lifting appl.
Single-impeller design		
2BH7210-0.N1	X	
2BH7210-0.N5		X
2BH7310-0.N2	X	
2BH7310-0.N6		X
2BH7410-0.N1	X	
2BH7410-0.N5		X
2BH7510-0.N2		X
2BH7510-0.N6		X
2BH7610-0.N3		X
Two-impeller design		
2BH7220-0.N5		X
2BH7320-0.N5		X
2BH7320-0.N8		X
2BH7420-0.N2		X
2BH7420-0.N5		X
2BH7520-0.N7		X
2BH7620-0.N3		X
2BH7620-0.N4		X
Three-impeller design		
2BH7630-0.N6		X

4 Installation

WARNING

Improper use of the pump-motor unit can result in serious or even fatal injuries!

Have you read the chapter "Safety instructions"? (📖 5)

Otherwise you may not carry out any work with or on the pump-motor unit!

DANGER!

Danger from missing view into area of pump-motor unit!

When operating the control elements without a view into the area of the pump-motor unit, there is a danger that the pump-motor unit will be switched on while other persons are still performing work on it. Severest injuries are possible!

Provide control elements at a location with a view of the pump-motor unit.

DANGER!

Electrical danger!

The pump-motor unit must be installed so that the electrical equipment cannot be damaged by external influences!

In particular, the incoming cables must be routed securely, e.g. in cable ducts, in the floor etc.

WARNING

Danger of balance damage caused by vibration!

Vibrating environments can cause balance damage!

Install the pump-motor unit on a solid foundation or on a solid mounting surface.

Check screw glands/unions for mounting the pump-motor unit on the mounting surface regularly for strength and firm seating.

WARNING

Danger of crushing due to pump-motor unit tipping over!

Wear personal safety equipment (safety gloves and safety shoes).

Handle the pump-motor unit with the appropriate care.

Install the pump-motor unit on a solid foundation or on a solid mounting surface!

Check screw glands/unions for mounting the pump-motor unit on the mounting surface regularly for strength.

WARNING

Danger of fire from flammable substances!

The pump-motor unit must never come into contact with flammable substances.

For exact information on the temperature increase see: (📖 12).

WARNING

Danger of burns from hot surface of the pump-motor unit and from hot media!

High temperatures of up to approx. 160 °C [320 °F] can occur on the surface of the pump-motor unit.

The pump-motor unit must be installed so that accidental touch of its surface is not possible. Cover the pump-motor unit with a suitable touch protection (e.g. perforated plate cover or wire cover).

WARNING

Danger of injuries from flying parts!

Select installation so that parts that are thrown out through the grate if the motor fan breaks cannot hit persons!

CAUTION

Danger of tripping and falling!

Make sure the pump-motor unit does not present a danger of tripping.

Lay cables and pipes so that they cannot be reached during operation (recessed in floor, in ducts on the wall etc.).

CAUTION**Danger of overheating due to hot surface of pump-motor unit!**

High temperatures can occur on the surface of the pump-motor unit.

Temperature-sensitive parts, such as cables or electronic components, may not come into contact with the surface of the pump-motor unit.

CAUTION**Danger of pump-motor unit damage caused by penetration of foreign bodies!**

On delivery all connection openings are closed in order to prevent the penetration of foreign bodies. Remove the seals right before the respective mounting step.

Installation sequence

The pump-motor unit is ready to connect on delivery.

CAUTION**The pump-motor unit may be damaged if it is installed and commissioned after longer storage periods without special preparation!**

If the pump-motor unit was stored for a longer period prior to installation, it has to be prepared for installation: (☞ 42)

Carry out the following steps to install the pump-motor unit:

- 1 Set up the pump-motor unit and attach it.
- 2 Mount the muffler (supplied loose) if necessary.
- 3 Mount the threaded flange or hose flange to the muffler if necessary.
- 4 Connect inlet and discharge connections to the system.
- 5 Establish electrical connection.

4.1 Installation**CAUTION****Pump-motor unit damage caused by incorrect mounting or use under impermissible ambient conditions!**

Install and connect the pump-motor unit only according to the instructions given in this chapter.

If the pump-motor unit is to be used under differing operating conditions, the manufacturer must be consulted.

NOTE

Dimensioned drawings with detailed dimensions, including fastening dimensions, are provided by the manufacturer.

4.1.1 Important notes**Ambient conditions**

The pump-motor unit is suitable for installation

- in a dusty or damp environment,
- in buildings,
- in the open.
 - For proper installation in the open, protect the pump-motor unit from exposure to intensive sunlight, e.g. by attaching a protective roof.
 - Further special protective devices against the effects of weathering are not required.

The motors of the units are to enclosure IP55. The insulation is tropic-proof.

Installation conditions

- Attach the pump-motor unit only to even surfaces.
- Do not exceed the maximum permissible vibration velocity $v_{eff} = 4\text{mm/s}$ [0.013 ft/s].
- Installation altitude max. 1000 m amsl [3280 ft amsl].
 - When installing at an altitude of more than 1000 m [3280 ft] above sea level, first inquire with the manufacturer.

Noise radiation

In order to reduce the noise radiation,

- do not mount pump-motor unit on noise-conducting or noise-radiating parts (e.g. thin walls or sheet-metal plates).
- provide pump-motor unit with sound-insulating intermediate layers (e.g. rubber buffers under the base of the pump-motor unit) if necessary.
- install the pump-motor unit on a stable foundation or on a rigid mounting surface. This will ensure quiet and low-vibration running of the pump-motor unit.

Components for reducing noise on the pump-motor unit:

- Muffler (included in the scope of supply)
 - On delivery the pump-motor units are equipped with attached mufflers as standard.
 - The mufflers considerably reduce the noise radiation.
- Additional muffler (available as accessories):
 - The additional mufflers enable a further noise reduction.
 - They may only be used in systems without piping, i.e. with direct intake out of the atmosphere or direct feeding into the atmosphere.
- Noise protection hoods (available as accessories):
 - Noise protection hoods are suitable for installation in rooms and in the open.
 - They reduce the overall sound pressure level and tonal components that are perceived as particularly annoying.

Installation variants

Units with motors without condensation water openings can be installed in different ways:

- horizontally,
- vertically on the cover of the side channel housing ("cover installation"),
- vertically on a wall.

CAUTION
<p>Danger of rusting due to collection of condensed water in drive motor area!</p> <p>Install and attach units with motors equipped with condensation water openings only horizontally, base at the bottom.</p>

4.1.2 Free spaces

CAUTION
<p>Material damage caused by overheating of the pump-motor unit!</p> <ul style="list-style-type: none"> • It is absolutely necessary to observe the required free spaces in order to cool the pump-motor unit sufficiently. • Ventilation screens and ventilation openings must remain clear. • The discharge air of other pump-motor units may not be directly sucked in again!

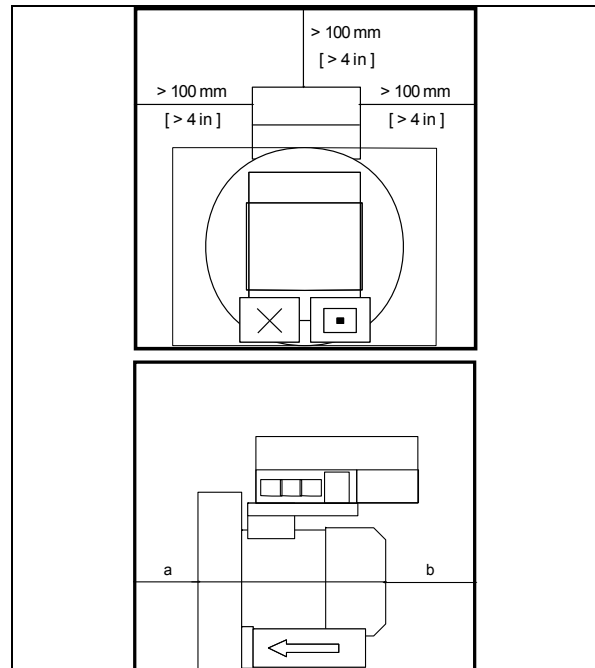

Type	a		b	
	[mm]	[in]	[mm]	[in]
2BH72..	> 30	> 1,18	> 34	> 1,34
2BH73..				
2BH74..			> 52	> 2,05
2BH75..				
2BH76..			> 53	> 2,09

Fig. 3: Free spaces

4.1.3 Mounting

NOTE

Dimensioned drawings with detailed dimensions, including fastening dimensions, are provided by the manufacturer.

Horizontal installation

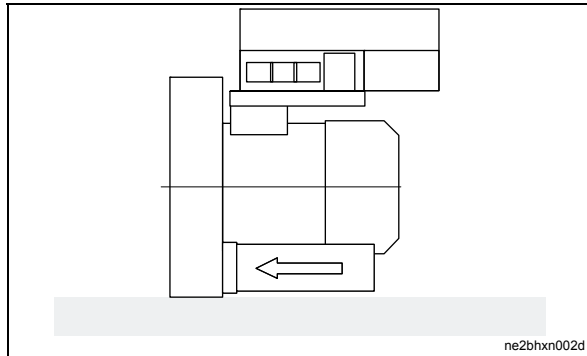

Fig. 4: Schematic diagram: horizontal installation

Mounting sequence:

- 1 Select suitable mounting elements.
- 2 Attach the pump-motor unit to the surface:
 - Screw the base of the pump-motor unit to the surface via the mounting holes.
 - When doing so, be sure to provide all mounting holes with screws!

Vertical installation on the cover of the gas ring blower ("cover installation")

NOTE

You need three rubber feet for the "cover installation" of the pump-motor unit. The rubber feet are available as accessories. They come with a stud bolt on one side and a threaded hole on the other side.

⚠ WARNING

Danger of crushing caused by pump-motor unit tipping over!

Avoid free-standing installation of the pump-motor unit!

Always screw the rubber feet to the foundation or to the installation surface!

Check screw connections regularly for tightness.

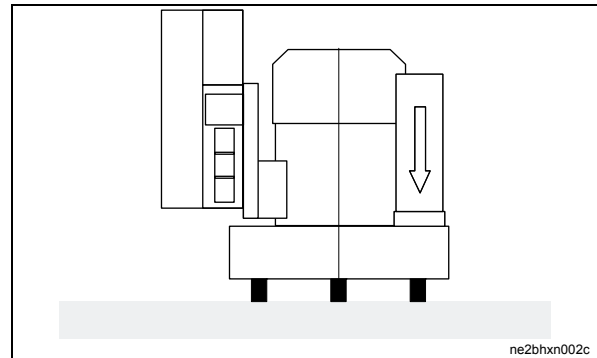

Fig. 5: Schematic diagram: installation on the cover of the side channel housing

Mounting sequence:

- 1 Attach the rubber feet to the pump-motor unit:
 - Screw the stud bolts of the rubber feet into the bore holes in the cover of the gas ring blower housing.
 - Tighten the rubber feet.
- 2 Mount the pump-motor unit together with the rubber feet on the installation surface:
 - Select suitable mounting elements for the threaded hole.
 - Screw the rubber feet to the installation surface via the threaded holes.

Vertical mounting on a wall

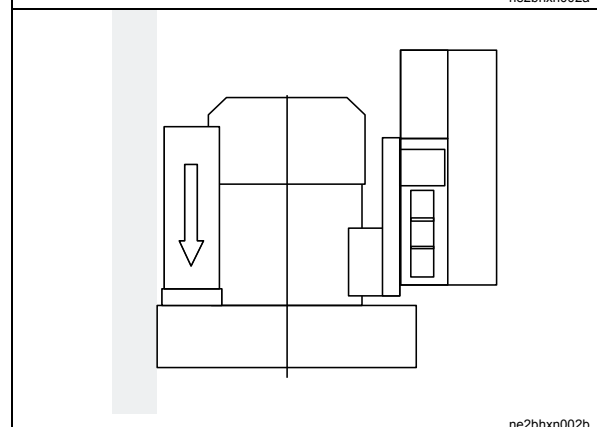
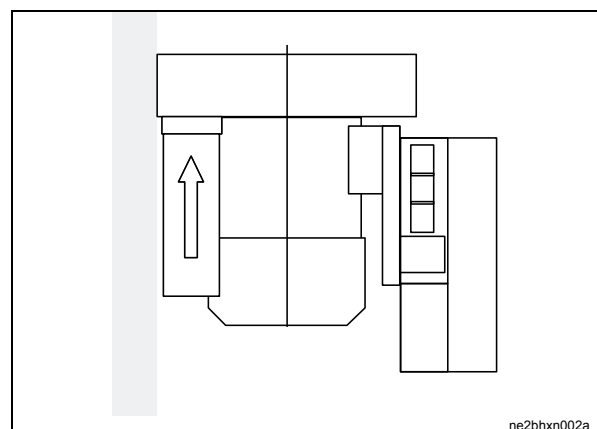

Fig. 6: Schematic diagram: vertical mounting on a wall

Mounting sequence:

- 1 Select suitable mounting elements.
- 2 Position the pump-motor unit as close to the wall as possible on a stable supporting plate with sufficient load-bearing capacity.
 - The pump-motor unit must be positioned with the base towards the wall.
- 3 Attach the pump-motor unit to the wall:
 - Screw the base of the pump-motor unit to the wall via the mounting holes.
 - When doing so, be sure to provide all mounting holes with screws!
- 4 Remove the supporting plate.

4.1.4 Final works

After installing the pump-motor unit, the eye bolt must be removed or screwed tightly.

4.2 Mounting of the muffler

The pump-motor units are supplied with mufflers for inlet and discharge connections as standard. The mufflers are marked by arrows in the following drawings.

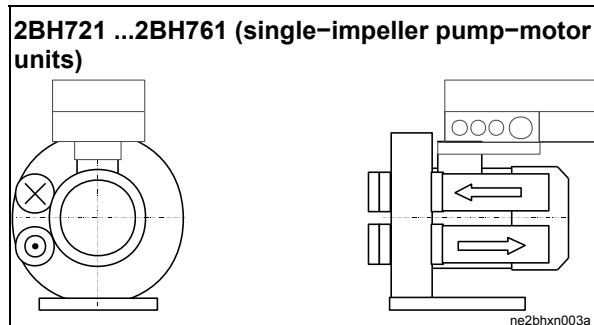

Fig. 7: Mounting of the muffler 2BH721 ...2BH761. With the following pump-motor units, the inlet-side muffler is included loose for packaging-related reasons. It must be mounted by the operator.

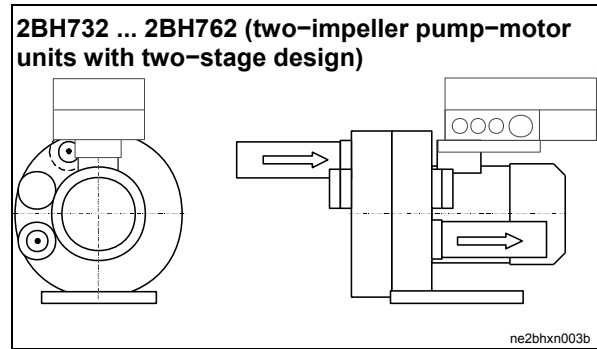

Fig. 8: Mounting of the muffler 2BH732 ... 2BH762

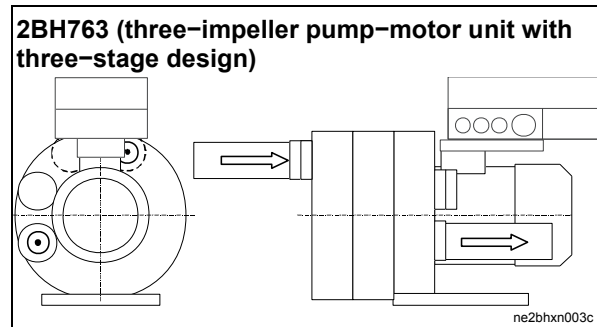

Fig. 9: Mounting of the muffler 2BH763

⚠ WARNING

Danger from rotating impeller: cutting/cutting off of extremities!

The rotating impeller is accessible with the inlet and discharge connections open!

With free entry and exit of gases, i.e. with direct intake out of the atmosphere or direct feeding into the atmosphere without piping, the following therefore applies:

Provide the inlet and discharge connections of the pump-motor unit either with additional mufflers or with additional piping of a sufficient length to prevent access to the impeller!

4.3 Connecting the pump-motor unit to the system

4.3.1 Important notes

Delivery direction of the gases

The pumped gases are sucked in via the inlet connection and discharged via the discharge connection.

The delivery direction of the gases is marked by arrows on the connections:

- The inlet connection with the corresponding muffler is marked by an arrow pointing into the pump-motor unit.
- The discharge connection with the corresponding muffler is marked by an arrow pointing out of the pump-motor unit.

Rotation direction of the shaft

The rotation direction of the shaft is marked by an arrow on the cover of the side channel housing and by an arrow on the fan guard of the motor.

WARNING

Danger from interchanging inlet and pressure line!

Interchanged inlet and pressure lines can lead to damage to the pump-motor unit and the system, and as a result of this to serious injuries!

Make sure that the inlet and the pressure line cannot be confused when connecting.

Pay attention to the clear marking with the arrows indicating the delivery direction on the inlet and discharge connections.

WARNING

Danger due to vacuum and gauge pressure! Danger due to escaping media!

During operation, connected pipes and vessels are vacuumized or pressurized!

Use only mounting elements, connections, lines, fittings and containers with sufficient freedom from leaks and strength for the pressures which occur.

Make sure that the mounting elements and connections are mounted firmly enough and leak-free!

CAUTION

If the pumped gases are passed on the discharge side in a closed pipe system, then it must be ensured that the pipe system is adapted to the maximum discharge pressure. Connect a pressure relief valve upstream if necessary.

NOTE

Attach pipes/hoses free of mechanical tensions.

- Support the weight of the pipes/hoses.

4.3.2 Connecting the inlet line

WARNING

Danger from solid bodies and impurities in the pump-motor unit!

If solid bodies penetrate into the pump-motor unit, blades of the impellers can break and broken pieces can be thrown out.

Install a filter in the inlet line. Replace filter regularly!

The pumped gases are taken in via the inlet line.

- Connect the inlet line to the inlet connection.
 - The inlet connection with the corresponding muffler is marked by an arrow pointing into the pump-motor unit.
- A If you use an inlet pipe, you can screw it directly into the muffler.
- B If you use an inlet hose, you need a hose flange available as accessories:
- Screw the hose flange to the muffler.
 - Push the hose onto the hose flange and secure it with a hose clamp.
 - Observe tightening torques ( 12)

4.3.3 Connecting the pressure line

The pumped gases are discharged via the pressure line.

- Connect the pressure line to the discharge connection.
 - The discharge connection with the corresponding muffler is marked by an arrow pointing out of the pump-motor unit.
- A If you use a pressure pipe, you can screw it directly into the muffler.
- B If you use a pressure hose, you need a hose flange available as accessories:
- Screw the hose flange to the muffler
 - Push the hose onto the hose flange and secure it with a hose clamp.
 - Observe tightening torques ( 12)

4.4 Electrical installation

⚠ DANGER!

Electrical danger!
Malpractice can result in severe injuries and material damage!

⚠ DANGER!

Electrical danger!
The electrical connection may be carried out by trained and authorized electricians only!

⚠ DANGER!

Electrical danger!
Before beginning work on the pump-motor unit or system, the following measures must be carried out:

- Deenergize.
- Secure against being switched on again.
- Determine whether deenergized.
- Ground and short-circuit.

Cover or block off adjacent energized parts.

⚠ DANGER!

Electrical danger!
The terminal box of the frequency inverter must be free from

- foreign bodies,
- dirt,
- humidity.

Frequency inverter and cable entries must be tightly closed so as to make them dustproof and waterproof. Check for tightness at regular intervals.

⚠ DANGER!

Electrical danger!
Danger of electrical shock when a defective pump-motor unit is touched!
Have electrical equipment checked regularly by a qualified electrician.

4.4.1 Important notes

Regulations

The electrical connection must be carried out as follows:

- according to the corresponding VDE regulations and national regulations.
- according to the applicable national, regional and system-dependent regulations and requirements.
- according to the regulations of the utility company applying to the place of installation.

Electrical power supply

Observe the rating plate of the frequency inverter. It is imperative that the operating conditions correspond to the data given on the rating plate.

Electrical connection (☞ 23), (☞ 26)

- The electrical connection must be permanently safe.
- The electrical connection to the PE conductor must be permanently safe.
- There may be no protruding wire ends.

Control cable connection (☞ 29)

- Use shielded incoming cables.
- Do not route control cables together with power cables in order to avoid interference injections.
- For optimum shielding use the shield connections to ensure large-surface contact when connecting the shield in the terminal box.
- Control cables

4.4.2 Preparing works

Open frequency inverter

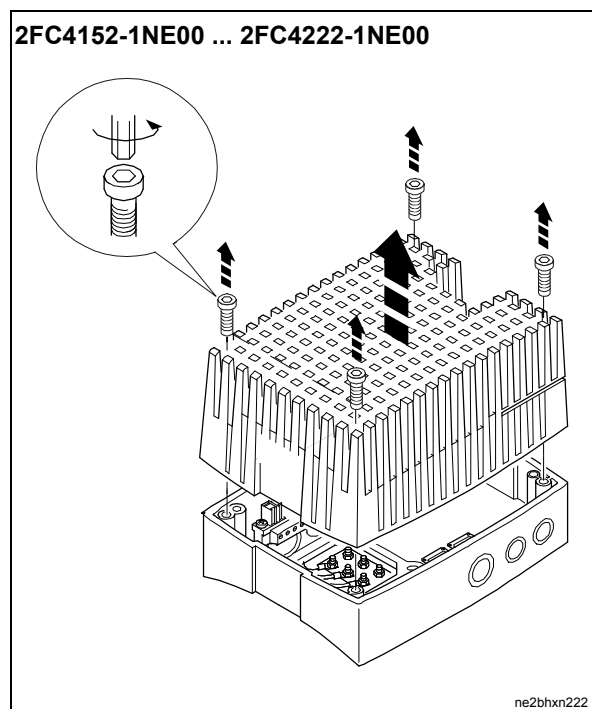

Fig. 10: Open frequency inverters 2FC4152-1NE00 and 2FC4222-1NE00

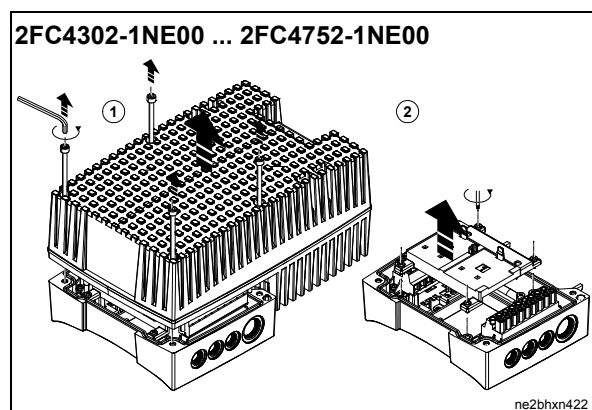

Fig. 11: Open frequency inverters 2FC4302-1NE00 ... 2FC4752-1NE00

4.4.3 Connecting frequency inverters 2FC4152-1NE00 and 2FC4222-1NE00

⚠ DANGER!

Electrical danger!

Improper connection of the pump-motor unit can result in an electric shock.

Observe the following basic rules:

- The leakage current to earth (PE) is >3.5 mA. The PE connection must meet EN 50178.
- Observe national and regional regulations.

CAUTION

Danger of pump-motor unit damage caused by improper connection!

Observe the permissible mains voltage. Any higher mains voltage will destroy the frequency inverter.

Wiring according to EMC requirements (installation of a CE-typical drive system)

The pump-motor units meet the EU Directive on "Electromagnetic Compatibility" if they are installed in accordance with the specifications of the CE-typical drive system. The end-user is responsible for maintaining the EU Directive in the overall system.

NOTE

Requirements for trouble-free operation:

- Always shield control cables.
- Provide large-surface contact between shielding and shield sheet. Ensure good electrical contact.

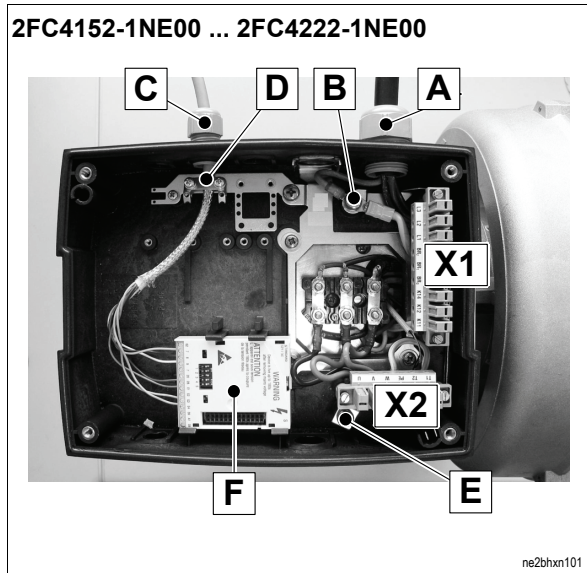
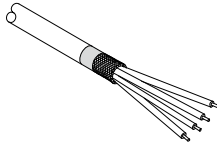

Fig. 12: Terminal box 2FC4152-1NE00 ... 2FC4222-1NE00

- A** Mains cable L1, L2, L3, PE
- B** PE connection mains cable and motor cable
- C** Shielded control cable
- D** Shield connection for the control cable::

1 Prepare cable



2 Pass the cable through the eye of the shield sheet and bend the eye.

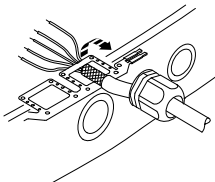

3 Screw together eye and shield sheet:

- The shielding must have large-surface contact to the shield sheet.
- The shielding must be connected tightly to the shield sheet.

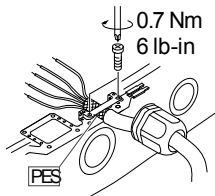

- E** Potential free terminal
- F** Control terminal module

- X1 Terminal strip for mains connection and relay output connection
- X2 Terminal strip for motor connection and motor temperature monitoring
- PES HF shield termination by large-surface connection to PE

Mains contactor, fuses and cable cross-sections

NOTE			
Observe the following when using earth leakage circuit breakers:			
<ul style="list-style-type: none"> Install earth leakage circuit breakers only between the supply mains and the frequency inverter. The earth leakage circuit breaker may trip incorrectly if several drives are simultaneously connected to the mains. 			

Frequency inverter	Required mains contactor K1				
Type	[kW]	[kW]			FI ²⁾
2FC4152-1NE00	1,5	4			≥30 mA
2FC4222-1NE00	2,2				
Frequency inverter	Fuses and cable cross sections				
	Installation according to EN 60204-1			Installation according to UL 1)	
Type	①	②	L1, L2, L3, PE [mm ²]	①	L1, L2, L3, PE [AWG]
2FC4152-1NE00	M6 A	B6 A	1	5 A	18
2FC4222-1NE00	M10 A	B10 A	1,5	10 A	16

- ① Fuse
- ② Circuit-breaker
- 1) Use only UL-approved cables, fuses and fuse holders. UL-fuse: voltage 500 ... 600 V, tripping characteristic "H", "K5" or "CC"
- 2) Pulse current sensitive or all current sensitive e.l.c.b.

Relay data

NOTE

The service life of the relay depends on the type of load (ohmic, inductive or capacitive) and the value of the switching capacity.

Technical data

AC 250 V/3 A

DC 24 V/2 A ... DC 240 V/0.22 A

	Function	Relay position switched	Displayed message
X1/K11	Relay output normally-closed contact	opened	TRIP
X1/K12	Relay mid-position contact		
X1/K14	Relay output normally-open contact	closed	TRIP
PES	HF shield termination by large-surface connection to PE		

Connection

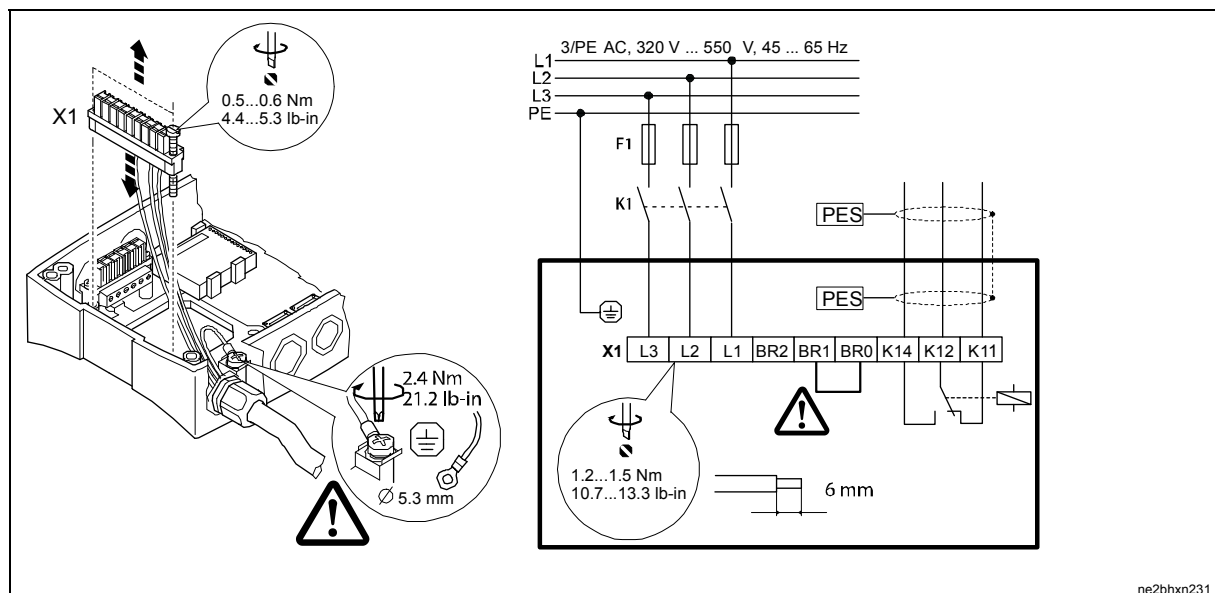

Fig. 13: Frequency inverter 2FC4152-1NE00 ... 2FC4222-1NE00 1 connecting

1 Connecting the mains cable:

- A Release two screws at terminal X1 and remove the terminal.
- B Pass the mains cable through the cable gland.
- C Attach the ring cable lug (□ 5.3 mm) to the PE conductor.
- D Screw the PE conductor onto the PE stud for the mains cable:
 - observe tightening torque!
- E Connect cores L1, L2 and L3 to X1 in correct phase relation:
 - observe tightening torque!

2 Wiring the relay output (if necessary):

- A Pass the cable through the cable gland.
- B Connect the shield of shielded cables according to EMC requirements (□ 24).
- C Connect cores to terminal X1:

- observe terminal connection diagram and tightening torque!

3 Re-insert terminal X1 and tighten with 2 screws:

- observe tightening torque!

4 Connecting the control cable shield:

- A Pass the control cable through the cable gland.
- B Connect the shield according to EMC requirements (□ 24).
- C Control cable connection: (□ 29)

5 Tighten all cable glands.

NOTE

Do not remove the jumper between terminals BR1 and BR0!
Otherwise trouble-free functioning of the pump-motor unit cannot be guaranteed.

**4.4.4 Connecting frequency inverters
2FC4302-1NE00 ... 2FC4752-1NE00**

 DANGER!

Electrical danger!

Improper connection of the pump-motor unit can result in an electric shock.

Observe the following basic rules:

- The leakage current to earth (PE) is > 3.5 mA. The PE connection must meet EN 50178.
- Observe national and regional regulations.

CAUTION

Danger of pump-motor unit damage caused by improper connection!

Observe the permissible mains voltage. Any higher mains voltage will destroy the frequency inverter.

**Wiring according to EMC requirements
(installation of a CE-typical drive system)**

The pump-motor units meet the EU Directive on "Electromagnetic Compatibility" if they are installed in accordance with the specifications of the CE-typical drive system. The end-user is responsible for maintaining the EU Directive in the overall system.

NOTE

Requirements for trouble-free operation:

- Always shield control cables.
- Provide large-surface contact between shielding and shield sheet. Ensure good electrical contact.

Realisation

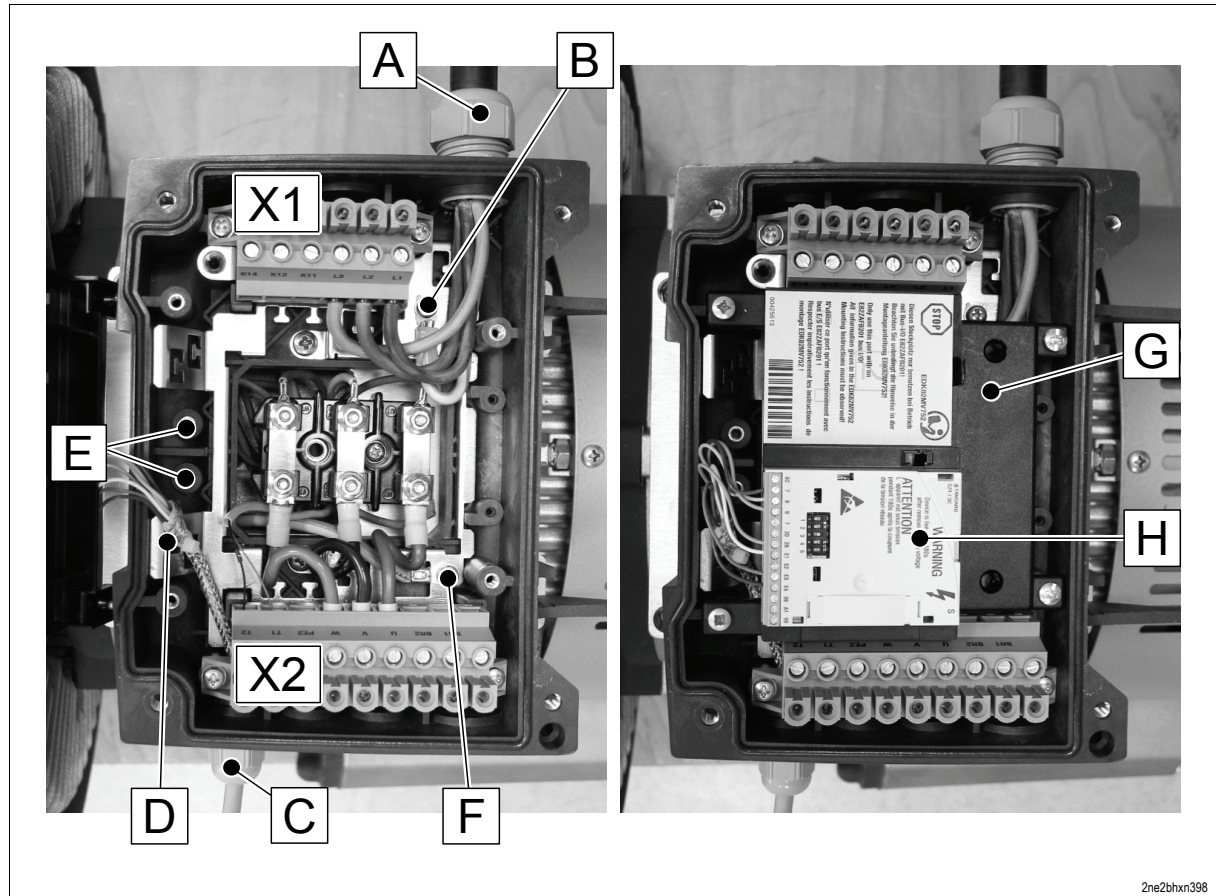
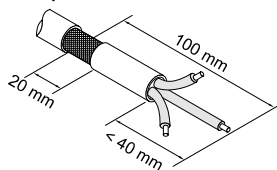

Fig. 14: Electrical connections 2FC4302-1NE00 ... 2FC4752-1NE00

- A** Mains cable L1, L2, L3, PE
- B** PE connection mains cable
- C** Shielded control cable
- D** Shield connection for the control cable: g:

1 Prepare cable..



2 Insert cable tie..

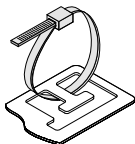

3 Insert cable and tighten cable tie:

- The shielding must have large-surface contact to the shield sheet.
- The shielding must be connected tightly to the shield sheet.

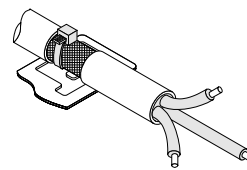

- E** Potential-free terminals
- F** PE connection motor
- G** Support for control terminal module
- H** Control terminal module
- X1 Terminal strip for mains connection and relay output connection
- X2 Terminal strip for motor connection
- PES HF shield termination by large-surface connection to PE

Mains contactor, fuses and cable cross-sections

NOTE			
Observe the following when using earth-leakage circuit breakers:			
<ul style="list-style-type: none"> • Install earth-leakage circuit breakers only between the supply mains and the frequency inverter. • The earth-leakage circuit breaker may trip incorrectly if several drives are simultaneously connected to the mains. 			

Frequency inverter	Required mains contactor K1				
Type	[kW]	[kW]	FI ²⁾		
2FC4302-1NE00	3	3	≥300 mA		
2FC4402-1NE00	4	4			
2FC4552-1NE00	5,5	5,5			
2FC4752-1NE00	7,5	7,5			
Frequency inverter	Fuses and cable cross sections				
	Installation according to EN 60204-1			Installation according to UL 1)	
Type	①	②	L1, L2, L3, PE [mm ²]	①	L1, L2, L3, PE [AWG]
2FC4302-1NE00	M16 A	B16 A	2,5	15 A	14
2FC4402-1NE00	M20 A	B20 A	4	20 A	12
2FC4552-1NE00	M25 A	B25 A	4	25 A	10
2FC4752-1NE00	M32 A	B32 A	6	35 A	8

- ① Fuse
- ② Circuit-breaker
- 1) Use only UL-approved cables, fuses and fuse holders. UL-fuse: voltage 500 ... 600 V, tripping characteristic "H", "K5" or "CC"
- 2) All-current sensitive e.l.c.b.

Relay data

NOTE			
The service life of the relay depends on the type of load (ohmic, inductive or capacitive) and the value of the switching capacity.			

Technical data

AC 250 V/3 A
 DC 24 V/2 A ... DC 240 V/0.22 A

	Function	Relay position switched	Displayed message
X1/K11	Relay output normally-closed contact	opened	TRIP
X1/K12	Relay mid-position contact		
X1/K14	Relay output normally-open contact	closed	TRIP
PES	HF shield termination by large-surface connection to PE		

Connection

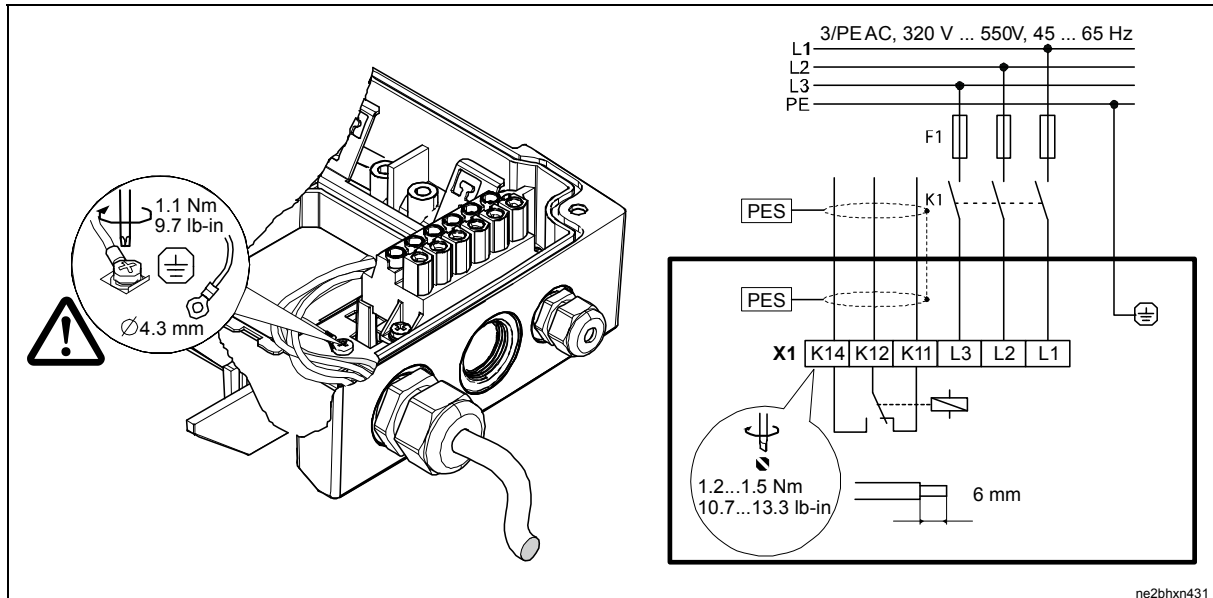

Fig. 15: Connecting frequency inverter 2FC4302-1NE00 ... 2FC4752-1NE00

1 Connecting the mains cable:

- A Pass the mains cable through the cable gland.
- B Attach the ring cable lug (\varnothing 4.3 mm) to the PE conductor.
- C Screw the PE conductor onto the PE stud for the mains cable:
 - observe tightening torque
- D Connect cores L1, L2 and L3 to X1 in correct phase relation:
 - observe tightening torque!

2 Wiring the relay output (if necessary):

- A Pass the cable through the cable gland.
- B Connect the shield of shielded cables according to EMC requirements (27).
- C Connect cores to terminal X1:
 - observe terminal connection diagram and tightening torque!

3 Connecting the control cable shield:

- A Pass the control cable through the cable gland.
- B Connect the shield according to EMC requirements (27).
- C Control cable connection: (29)

4 Tighten all cable glands.

4.4.5 Wiring of control connections

The control connections are on the control terminal module 2FX4501-0NE00 which is included in the scope of supply.

Install the control terminal module in the terminal box of the frequency inverter before starting to wire the control connections.

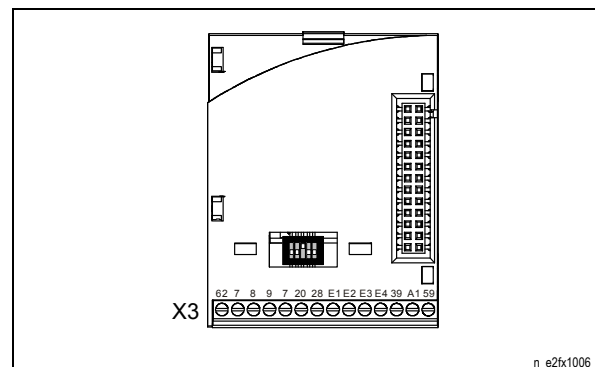

Fig. 16: Control connections 2FX4501-0NE00

Mount control terminal module

CAUTION

If the cap is plugged on the socket connector when assembling the frequency inverter, the control terminal module will be damaged!

- Remove the cap from the socket connector at the control terminal module.
- Keep the cap.

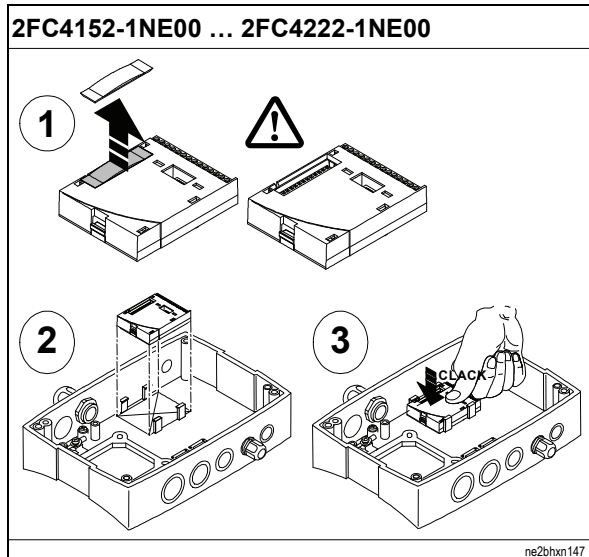

Fig. 17: Control terminal module installation in frequency inverters 2FC4152-1NE00 and 2FC4222-1NE00

Screw terminal data

Electrical connections	Terminal strip with screw connection	
Possible connections		rigid: 1,5 mm ² (AWG 16)
		flexible: without wire end ferrule 1,0 mm ² (AWG 18)
		without wire end ferrule, without plastic sleeve 0,5 mm ² (AWG 20)
		with wire end ferrule, with plastic sleeve 0,5 mm ² (AWG 20)
Tightening torque	0,22 ... 0,25 Nm (1,9 ... 2,2 lb-in)	
Bare end	5 mm	

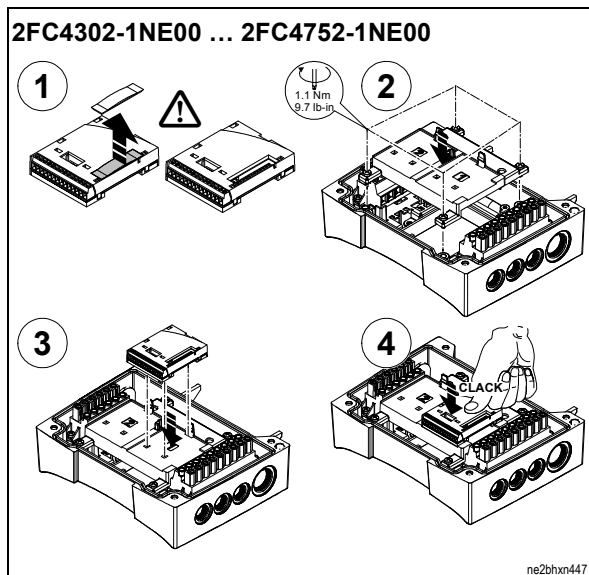

Fig. 18: Control terminal module installation in frequency inverters 2FC4302-1NE00 ... 2FC4752-1NE00

Wiring

NOTE

Always shield control cables in order to avoid interference injections!

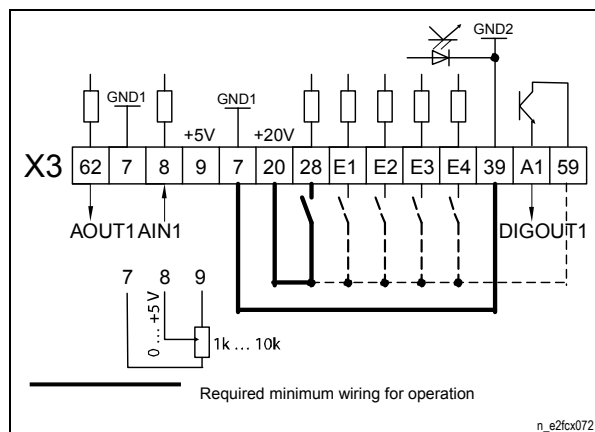

Fig. 19: Supply via the internal voltage source (X3/20)

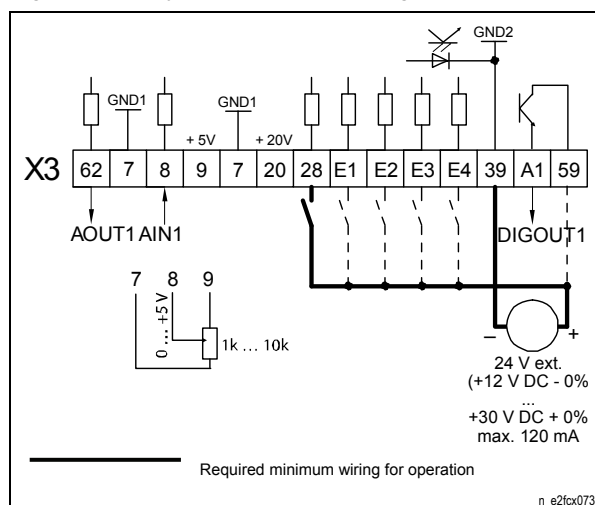
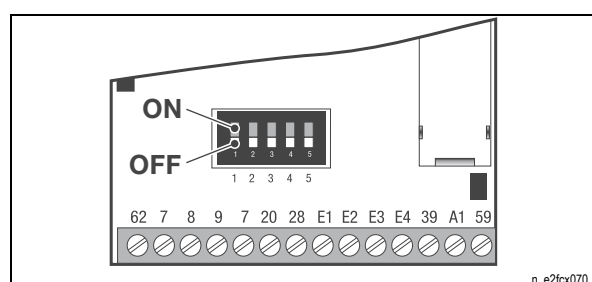

Fig. 20: Supply via an external voltage source

Terminal assignment

X3/	Signal type	Function	Level		
X3/62	Analog output	Output frequency	0 ... + 6 V		
X3/7	-	GND1, reference potential for analog signals	-		
X3/8	Analog input	Setpoint input Change setpoint selection range via DIP switch	0 ... +5 V (default setting) 0 ... +10 V 0 ... +20 mA		
X3/9	-	Internal, stabilised DC voltage source for setpoint potentiometer	+5,2 V (ref.: X3/7)		
X3/20	-	Internal DC voltage source to control digital inputs and digital outputs	+20 V ± 10 % (ref.: X3/7)		
X3/28	Digital inputs	Controller inhibit	HIGH ⇔ START LOW ⇔ STOP		
X3/E1		Reset fault (TRIP-Reset)	HIGH ⇔ Reset fault		
X3/E2		External fault	HIGH ⇔ Switch-off with fault indication "EEr" LOW ⇔ No fault		
X3/E3		Activation of fixed speeds		E3	E4
X3/E4	Adjust maximum frequency C0011 in order to go through the complete speed range. Maximum value of C0011 = 87 Hz (5000/min)	34 Hz (2000/min)	HIGH	LOW	
		67 Hz (4000/min)	LOW	HIGH	
		50 Hz (3000/min)	HIGH	HIGH	
X3/39	-	GND2, reference potential for digital signals	-		
X3/A1	Digital output	"Pulse inhibit active" message	HIGH ⇔ pulse inhibit active		
X3/59	-	DC supply for X3/A1	+20 V	Internal voltage source (jumper to X3/20)	
			+24 V	External voltage source	



Signal at X3/8	Switch position				
	1	2	3	4	5
0 ... 5 V (default setting)	OFF	OFF	ON	OFF	OFF
0 ... 10 V	OFF	OFF	ON	OFF	ON
0 ... 20 mA	OFF	OFF	ON	ON	OFF

Fig. 21: Switch position control terminal module

Electrical data of the terminals

X3/		
X3/62	Resolution	10 bits
	Linearity error	±0,5 %
	Temperature error	0,3 % (0 ... +60°C)
	Load capacity	$I_{max} = 2 \text{ mA}$
X3/8	Resolution	10 bits
	Linearity error	±0,5 %
	Temperature error	0,3 % (0 ... +60°C)
	Load capacity	$I_{max} = 2 \text{ mA}$
	Input resistance	Voltage signal: >50 kΩ Current signal: 250 Ω
X3/9	Load capacity	$I_{max} = 10 \text{ mA}$
X3/7	Isolated from terminal X3/39 (GND2)	
X3/28	Load capacity	3,3 kΩ
	HIGH	+12 ... +30 V, SPS- level, HTL
X3/E1	LOW	0 ... +3 V, SPS- level, HTL
... X3/E4		
X3/39	Isolated from terminal X3/7 (GND1)	
X3/A1	Load capacity	For internal supply: $I_{max} = 10 \text{ mA}$ For external supply: $I_{max} = 50 \text{ mA}$

CAUTION

Improper closing of the frequency inverter may damage the contacts of the control terminal module.

Observe the following points to avoid damages:

- Place the heatsink of the frequency inverter carefully on the terminal box.
- Place the heatsink upright on the terminal box from above, do not tilt it!
- When placing the heatsink upon the terminal box, pay attention to placing the plug at the heatsink exactly upon the socket connector at the control terminal module.
- Never force the heatsink upon the terminal box.

CAUTION

If the cap is plugged on the socket connector when assembling the frequency inverter, the control terminal module will be damaged!

- Remove the cap from the socket connector at the control terminal module.
- Keep the cap..

4.4.6 Final works

Close frequency inverter

⚠ DANGER!

Electrical danger!

The terminal box of the frequency inverter must be free from

- foreign bodies,
- dirt,
- humidity.

Frequency inverter and cable entries must be tightly closed so as to make them dustproof and waterproof. Check for tightness at regular intervals.

⚠ DANGER!

Electrical danger!

Danger of electrical shock when a defective pump-motor unit is touched!

Have electrical equipment checked regularly by a qualified electrician.

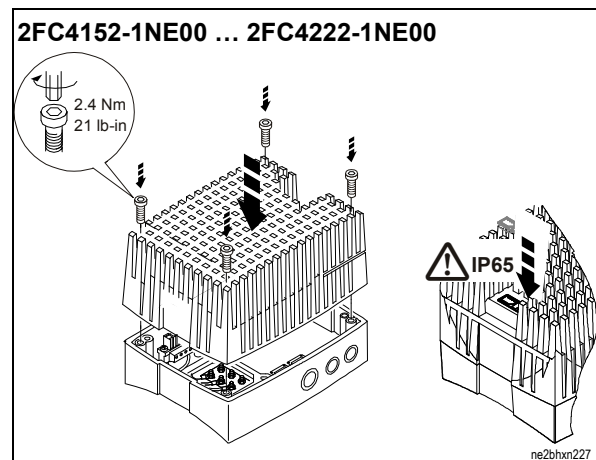

Fig. 22: Close frequency inverters 2FC4152-1NE00 and 2FC4222-1NE00

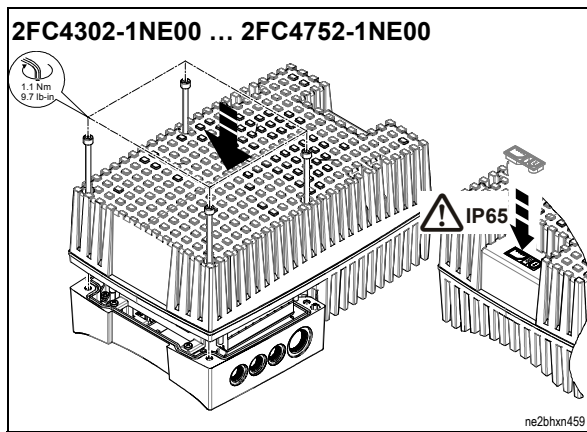

Fig. 23: Close frequency inverters 2FC4302-1NE00
... 2FC4752-1NE00

5 Commissioning

WARNING

Improper use of the pump-motor unit can result in serious or even fatal injuries!

Have you read the chapter "Safety instructions"? (📖 5)

Otherwise you may not carry out any work with or on the pump-motor unit!

WARNING

Danger from rotating parts (motor fan, impeller, shaft): cutting/cutting off of extremities, grasping/winding up of hair and clothing!

Danger due to vacuum and gauge pressure: sudden escape of media (skin and eye injuries), sudden drawing-in of hair and clothing!

Danger due to escaping media: burns!

Commissioning and operation only under the following conditions:

- The pump-motor unit must be completely assembled. When doing so, pay particular attention to the following components:
 - the cover of the gas ring blower housing,
 - the mufflers on inlet and discharge connections,
 - the fan guard.
- The pipes/hoses must be connected to inlet and discharge connections.
- Inlet and discharge connections and the connected pipes/hoses may not be closed, clogged or soiled.
- Check the mounting elements, connections of the pipe/hose connections, lines, fittings and containers for strength, leaks and firm seating at regular intervals.

5.1 Preparation

WARNING

Danger from closed connections!

With closed/soiled inlet or discharge connections vacuum or gauge pressure results in the pump-motor unit.

This can overheat and damage the drive motor winding.

Before commissioning, make sure that the inlet and discharge connections are not closed, clogged or soiled!

CAUTION

Before starting up again after a longer standstill:

- Measure the insulation resistance of the motor.
- With values $< 1 \text{ k} \quad / \text{Volt of rated voltage}$, the winding is to dry.

Measures before start-up:

- If a shut-off device is installed in the pressure line: make sure that the pump-motor unit is NOT operated with the shut-off device being closed.
- Observe the values specified on the rating plate before starting up the pump-motor unit. Specifications on the rated motor current apply at a gas entry and ambient temperature of $+40^\circ \text{C}$ [104°F].

WARNING

Danger due to rotating parts!

Danger due to vacuum and gauge pressure!

Danger due to escaping media!

Test runs may only be conducted with the pump-motor unit completely mounted.

DANGER!

Electrical danger!

The electrical connection may be carried out by trained and authorized electricians only!

⚠ DANGER!**Electrical danger!**

Before beginning work on the pump-motor unit or system, the following measures must be carried out:

- Deenergize.
- Secure against being switched on again.
- Determine whether deenergized.
- Ground and short-circuit.
- Cover or block off adjacent energized parts.

Check operating speeds:

Observe the maximum speed specified on the rating plate.

This speed may not be exceeded, as otherwise the noise radiation, vibration behavior, grease change interval and bearing change interval worsen.

To prevent damage as a result of higher speeds, it may be necessary to inquire with the manufacturer as to the maximum speed.

⚠ WARNING**Danger of hearing damage due to noise radiation!**

The noise emission of the pump-motor unit measured by the manufacturer is specified under "Technical data" (11).

The actual noise emission during operation, however, strongly depends on the installation type and on the system conditions.

For this reason conduct a noise measurement in the system during operation after installing the pump-motor unit.

The following measures must be taken by the operator:

- from 85 dB(A):
 - Hearing protection must be available.
- from 90 dB(A):
 - Mark noise area with a warning sign.
 - Wear hearing protection.
 - With free entry and exit of gases, i.e. with direct intake out of the atmosphere or direct feeding into the atmosphere without piping, attach an additional muffler.

5.2 Parameter setting**5.2.1 The hand-held keypad 2FX4506-0NE00****Description**

The hand-held keypad is available as accessories. A complete description is part of the Instructions supplied with the hand-held keypad.

Installation/ commissioning

Fig. 24: Installation/commissioning hand-held keypad

- ① Connect hand-held keypad to control interface using the connecting cable. The hand-held keypad can be connected and disconnected during operation.
- ② As soon as the keypad is supplied with voltage, it carries out a short self-test.
- ③ The keypad is ready for operation when it is in display mode **Disp**:
 - A** Current state of the frequency inverter
 - B** First code in the menu
 - C** Controller load (each graduation mark = 20 %)
- ④ Press **▲** to leave the **Disp** mode

Display elements and function keys

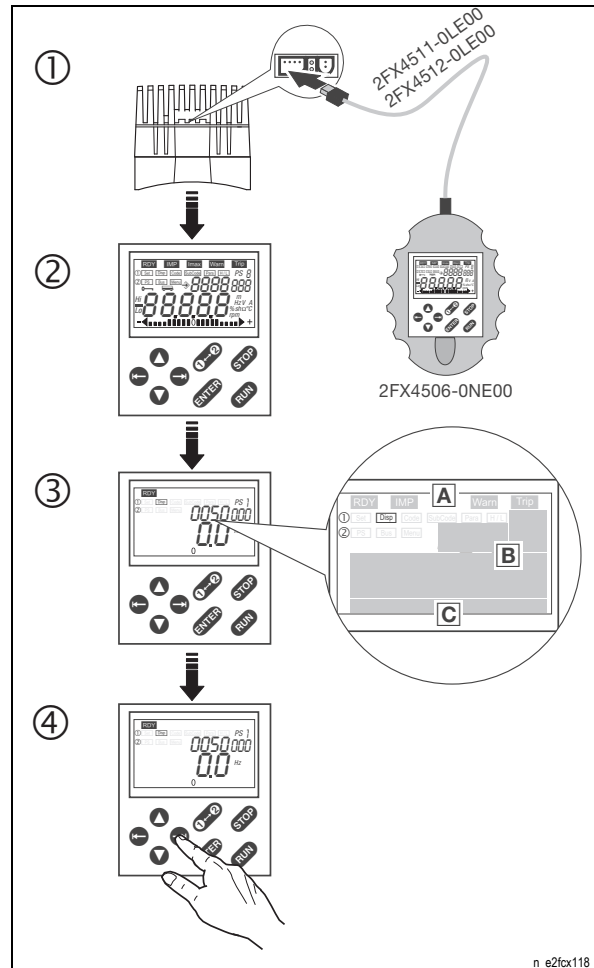
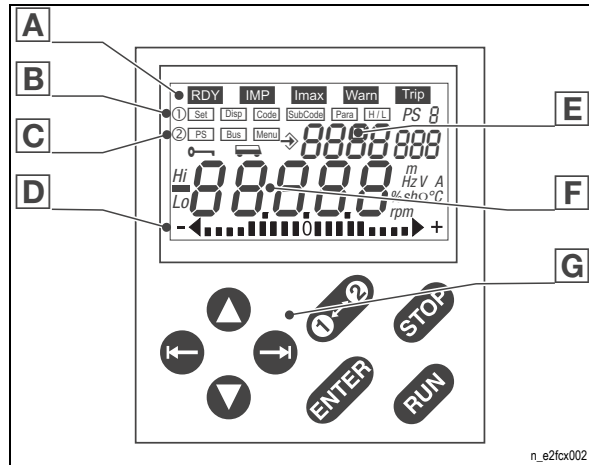

Fig. 25: Display elements and function keys

G Function keys		
	Function	Explanation
	Enable controller	Terminal X3/28 must additionally be at HIGH level
	Inhibit controller	
	Change function bar 1 function bar 2	Function bar 2 not active
	To right/left in active function bar	The active function is framed
	Increase/decrease value	Only blinking values can be changed
	Fast change: Keep respective key pressed	
	Store parameters when ! is blinking	Confirmation by Store in display

A Status displays		
	Meaning	Explanation
	Ready	
	Pulse inhibit active	Power outputs inhibited
	Adjusted current limitation is exceeded in motor-mode or generator mode	C0022 (motor mode) or C0023 (generator mode)
	Warning active	
	Fault active	
B Function bar 1		
	Meaning	Explanation
	Without function	Display = loc
	Display of first code in the menu	Active after every mains connection
	Code selection	Four-digit display of the active code number
	Without function	Is skipped
	Change of parameter value of a code	Five-digit display of the current value
	Without function	
C Function bar 2		
	Not active	
D Bar graph display		
	Controller load	Display range: -180 % ... +180 % (each graduation mark = 20 %)
E Display of code number		
F Display of parameter value or fault indication		

Changing and saving parameters

All parameters for parameterization or monitoring of the controller are stored in codes. The codes are numbered and marked with a "C" in the documentation. The available codes are listed in the code table.

Step	Keys	Result	Action
1. Connect keypad		 XX.XX Hz	The function is active. C0140 = setpoint is indicated via keypad.
2. Set parameters			Select mode "
3.		XXXX	Select code..
4.			Modus off Ahlen.
5.		xxxxx	Parameter onstellen.
6.		Store	Confirm entry when ! is blinking.
			Confirm entry when ! is not blinking; is inactive.
7.			Start "loop" again at 2. for further parameter setting.
Changed parameters are stored in the non-volatile memory of the controller.			

5.2.2 Code table

How to read the Code table

Column	Abbreviation	Meaning
Code	Cxxxx	Code number Cxxxx
		The parameter value is accepted immediately (ONLINE)
		Changed parameter of the code will be accepted after pressing if the controller is inhibited
Designation		Name of the code
Manufacturer		Default setting (value at delivery or after restoring default setting via C0002)
	→	Further information can be obtained from "IMPORTANT"
Selection	1 {%} 99	Min. value {unit} max. value
IMPORTANT	-	Brief, important explanations

Code		Possible settings			IMPORTANT	
No.	Designation	Manu- facturer	Selection			
C0140	Setpoint offset via keypad	0,00	-650,00	{0,02 Hz}	650,00	Acts additively on <ul style="list-style-type: none"> main setpoint. setpoint 2. fixed speeds (JOG). The set value is stored in case of mains switching or keypad removal.
C0050	Output frequency		-650,00	{Hz}	650,00	Display only: Output frequency without slip compensation
C0052	Motor voltage		0	{V}	1000	Display only
C0054	Apparent motor current		0,0	{A}	2000,0	Display only







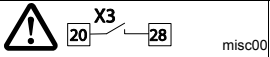

Code		Possible settings			IMPORTANT	
No.	Designation	Manufacturer	Selection			
C0010	Minimum output frequency	10,00	0,00	{0,02 Hz}	650,00	C0010 only limits the analog input 1
C0011	Maximum output frequency	→				→ Only valid for units 2BH.–..N.1–. and 2BH.–..N.3–.with integrated 2FCxxxx–1NE00 inverter
		86,00	7,50	{0,02 Hz}	650,00	Maximum permissible value: 86 (5000/min)
C0012	Acceleration time main setpoint	→				→ Only valid for units 2BH.–..N.1–. and 2BH.–..N.3–.with integrated 2FCxxxx–1NE00 inverter
		10,00				Setting for units up to 5.5 kW
		25,00				Setting for 7.5 kW unit
			0,00	{0,02 s}	1300,00	Reference: frequency change 0 Hz ... C0011
C0013	Deceleration time main setpoint	→				→ Only valid for units 2BH.–..N.1–. and 2BH.–..N.3–.with integrated 2FCxxxx–1NE00 inverter
		10,00				Setting for units up to 5.5 kW
		20,00				Setting for 7.5 kW unit
			0,00	{0,02 s}	1300,00	Reference: frequency change 0 Hz ... C0011
C0015	U/f–rated frequency	→				→ Only valid for units 2BH.–..N.1–. and 2BH.–..N.3–.with integrated 2FCxxxx–1NE00 inverter
		52,70				Setting for units 2BH.–..N.3–.
		90,90				Setting for units 2BH.–..N.1–.
			7,50	{0,02 Hz}	960,00	$C0015 [Hz] = \frac{U_N [V]}{U_r [V]} * f_r [Hz]$ <ul style="list-style-type: none"> • U_N = mains rated voltage of inverter • U_r = rated voltage of motor depending on connection method acc. to rating plate • f_r = rated frequency of motor acc. To rating plate The setting applies to the entire mains voltage range in which the inverter may be operated.
C0016	$U_{min,boost}$ (starting voltage)	→	0,00	{0,01 %}	40,00	→ Depends on the device Load–independent rise of motor voltage at low speeds: <ul style="list-style-type: none"> • Reference: rated voltage of motor (C0090). • The setting applies to the entire mains voltage range in which the inverter may be operated.

5.3 Start-up of the pump-motor unit

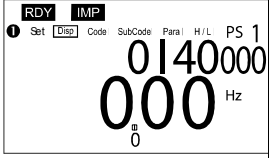
The description of how to change pre-set parameters using the hand-held keypad starts on page 35.

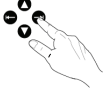
NOTE

- When no setpoint has been entered, the drive rotates with the minimum frequency set under C0010!
- The setpoint offset set under C0140 is stored and will be active at each switch-on.
- The setpoint offset set under C0140 has an additive effect on all other setpoints!
- This effect can be used, for example, to set speeds between fixed speeds:
 - Fixed speed via terminal = 67 Hz (4000/min)
 - C0140 = -7 Hz
 - Resulting speed = 60 Hz (3600/min)

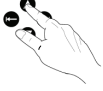
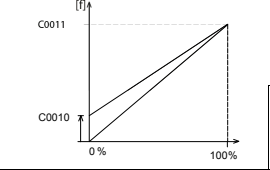
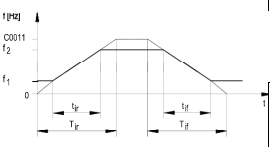
Switch-on sequence		Note
1. Connect keypad.		
2. Ensure that controller inhibit is active after mains connection.		Terminal X3/28 = LOW
3. Open the shut-off device in the inlet line or in the pressure line..		
4. Switch on the mains.		
5. The keypad is in "Disp" mode after approx. 2 s and indicates the setpoint offset (C0140).		
6. Change to the Code mode with  in order to set drive parameters.		0140 is blinking in the display.
7. Press    .		Thus, you skip the display codes for output frequency (C0050), motor voltage (C0052) and apparent motor current (C0054).
8. Set the minimum output frequency (C0010). Default setting: 10.00 Hz (600/min)		After controller enabling, the motor at least rotates with the frequency set under C0010!
9. Set the maximum output frequency (C0011). Default setting: 86.00 Hz (3000/min)		
10. Set acceleration time T_{ir} (C0012). Default setting: 10 00 s: frequency inverters up to 5 kW 25.00 s: frequency inverter 7.5 kW		$T_{ir} = t_{ir} * \frac{C0011}{f_2 - f_1}$ t_{ir} = desired acceleration time
11. Set deceleration time T_{if} on (C0013). Default setting: 10 00 s: frequency inverters up to 5.5 kW 20.00 s: frequency inverter 7.5 kW		$T_{if} = t_{if} * \frac{C0011}{f_2 - f_1}$ t_{if} = desired deceleration time

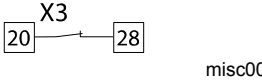
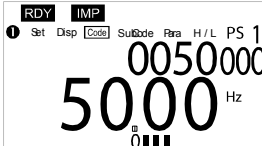
The base settings are now completed and the drive can be started:			
Start drive		Note	
12.	Enter the setpoint.		
	A) Using the keypad		Set desired output frequency under C0140. The min. frequency under C0010 and the setpoint offset under C0140 are added!
	B) Using the potentiometer via terminals 7, 8, 9		
	C) Enter fixed speed via terminal.	Terminal	E3 E4
		34 Hz (2000/min)	HIGH LOW
		67 Hz (4000/min)	LOW HIGH
		50 Hz (3000/min)	HIGH HIGH
13.	Enable controller.		Terminal X3/28 = HIGH
14.	The drive now operates with the set frequency. The current output frequency is indicated under C0050.		If the drive does not start, press RUN in addition.

5.4 Shut-down of the pump-motor unit

Shut-down:

- 1 Set controller inhibit (terminal X3/28 = LOW)
- 2 Switch off power supply.
- 3 Close shut-off device in inlet/ pressure line.

6 Operation

WARNING

Improper use of the pump-motor unit can result in serious or even fatal injuries!

Have you read the chapter "Safety instructions"? (📖 5)

Otherwise you may not carry out any work with or on the pump-motor unit!

CAUTION

Danger of bearing damage!

Heavy mechanical impacts must be avoided during operating and while at a standstill.

Start-up and shut-down

See chapter Commissioning: (📖 34)

Important notes during operation

WARNING

Danger of burns from hot surface of the pump-motor unit and from hot media!

High temperatures of up to approx. 160 °C [320 °F] can occur on the surface of the pump-motor unit.

Do not touch during operation. Allow to cool after shut-down.

CAUTION

Danger of overheating due to hot surface of pump-motor unit!

High temperatures of up to approx. 160 °C [320 °F] can occur on the surface of the pump-motor unit.

Temperature-sensitive parts such as cables or electronic components may not come into contact with the surface of the pump-motor unit.

CAUTION

Danger of overheating!

During operation the standstill heating may, if installed, not be switched on!

CAUTION

Danger of rusting due to collection of condensed water in drive motor area!

On drive motors with closed condensed water openings:

Remove closures occasionally to allow any water which has collected to drain off.

7 Shut-down and longer standstills

 WARNING
<p>Improper use of the pump-motor unit can result in serious or even fatal injuries!</p> <p>Have you read the chapter "Safety instructions"? (📖 5)</p> <p>Otherwise you may not carry out any work with or on the pump-motor unit!</p>

7.1 Preparation

CAUTION
<p>Danger of rusting due to collection of condensed water in drive motor area!</p> <p>On drive motors with closed condensed water openings:</p> <p>Remove closures occasionally to allow any water which has collected to drain off.</p>

Prior to shut-down or longer standstill, proceed as follows:

- 1 Switch off the pump-motor unit.
- 2 Close shut-off device in inlet and pressure line (if installed).
- 3 Disconnect pump-motor unit from power supply.
- 4 Druckentlastung vornehmen.
Dabei Rohrleitungen / Schläuche langsam und vorsichtig öffnen, so dass sich der Unter- bzw. Überdruck im Aggregat abbauen kann.
- 5 Disconnect inlet line and pressure line.
- 6 Provide mufflers on inlet and discharge side with sealing plugs.

7.2 Storage conditions

Keep to the following storage conditions to avoid damaging the pump-motor unit:

- Dry,
- Dust-free,
- Low-vibration (max. vibration velocity $v_{\text{eff}} = 2,8$ mm/s [0,009 ft/s]).
- Ambient temperature: max. 40°C [+104°F].

CAUTION
<p>Danger of overheating due to high temperature!</p> <p>When storing in an environment with a temperature of over 40 °C [104 °F], the winding may be damaged and the grease change interval may be shortened.</p>

Lubrication of the rolling bearings after longer storage

The new pump-motor unit may at first be stored following delivery.

If the time from delivery to commissioning exceeds the following periods, the lubrication of the rolling bearings must be renewed:

- Under advantageous storage conditions (as specified above):
 - 4 years
- Under disadvantageous storage conditions (e.g. high humidity, salty air, sandy or dusty air):
 - 2 years

In these cases open rolling bearings must be relubricated and closed rolling bearings must be completely replaced.

This absolutely requires consultation of the manufacturer. In particular detailed information regarding the procedure and the grease type is required.

 WARNING
<p>Improper use of the pump-motor unit can result in serious or even fatal injuries!</p> <p>All maintenance work on the pump-motor unit must always be performed by the Service Department!</p> <p>Maintenance work on the pump-motor unit may only be conducted by the operator when the related maintenance manual is on hand!</p> <p>Inquire with the manufacturer!</p>

Commissioning after longer standstill or longer storage:

Before re-commissioning after longer standstill or longer storage, the following works must be executed:

- Measure the insulation resistance of the motor. With values ≤ 1 k Ω per volt of rated voltage, the winding is to dry.
- Form the capacitors of the frequency inverter. Please contact the manufacturer for this purpose.

8 Servicing

 WARNING
<p>Improper use of the pump-motor unit can result in serious or even fatal injuries!</p> <p>Have you read the chapter "Safety instructions"? (📖 5)</p> <p>Otherwise you may not carry out any work with or on the pump-motor unit!</p>

 WARNING
<p>Improper use of the pump-motor unit can result in serious or even fatal injuries!</p> <p>All maintenance work on the pump-motor unit must always be performed by the Service Department!</p> <p>Maintenance work on the pump-motor unit may only be conducted by the operator when the related maintenance manual is on hand! Inquire with the manufacturer!</p>

8.1 Repair/ troubleshooting

8.1.1 Malfunctions at side channel blower

Malfunction	Cause	Remedy	Carried out by
Frequency inverter assumes fault mode after controller enable See also: 📖 45	Impeller is jammed.	Open blower cover, remove foreign body, clean.	Service*)
		Check or correct impeller gap setting if necessary.	Service*)
	Impeller defective.	Replace impeller.	Service*)
	Rolling bearing on drive motor side or blower side defective.	Replace motor bearing or blower bearing.	Service*)
	Throttling does not match specification on rating plate.	Reduce throttling. Clean filters, mufflers and connection pipes if necessary.	Service*) Service*)
Side channel blower does not start	One power supply lead interrupted.	Eliminate interruption by fuses, terminals or power supply cables	Electrician
	DC-bus voltage too low. (Red LED blinking fast, keypad display: Lu)	Check mains voltage	Electrician
	Controller inhibited. (Green LED blinking, keypad display: IMP)	Remove controller inhibit. Controller inhibit can be set through several sources.	Operator
	Setpoint = 0.	Enter the setpoint.	Operator
	Active fault	Eliminate fault	Electrician Operator
Side channel blower rotates unsteadily	Defective motor cable	Check motor cable	Electrician
	Motor underexcited or overexcited.	Check parameter setting (C0015, C0016).	

Malfunction	Cause	Remedy	Carried out by
Side-channel blower does not reach the required speed / pump-motor unit does not generate pressure difference or generated difference is too low	Leak in system.	Seal leak in the system.	Operator
	Shaft seal defective.	Replace shaft seal.	Service*)
	Different density of pumped gas.	Take account of the conversion of the pressure values. Inquire with Service Department.	Service
	Change in blade profile due to soiling.	Clean impeller, check for wear and replace if necessary.	Service*)
	Setpoint range wrongly adjusted at DIP switch.	Adjust setting of DIP switch to the analog signal	Electrician
Side channel blower operates, setpoints "0"	Setting of maximum output frequency too low.	Increase C0011. Max. permissible value= 87 Hz (5000/min) for 2BH11 ... 2BH18. Max. permissible value= 70 Hz (4200/min) for 2BH19	Electrician Operator
	Min. output frequency set > 0 Hz. (Default setting= 10 Hz)	Change drive characteristics only under special circumstances! (Set C0010 = 0 Hz)	Electrician Operator
Current consumption of motor too high	In C0140 a setpoint has been set. (Setting of C0140 stored in non-volatile memory)	Set C0140 = 0 Hz if necessary..	Electrician Operator
	C0016 set too large or too small.	Correct setting	Electrician Operator
Abnormal flow noises	Flow speed too high.	Clean pipes. Use pipes with larger cross-section if necessary.	Operator
	Muffler soiled.	Clean muffler inserts, check condition and replace if necessary.	Service*)
Abnormal running noise	Ball bearing lacking grease or defective.	Regrease or replace ball bearing.	Service*)
Blower leaky	Seals on muffler defective.	Check muffler seals and replace if necessary.	Service*)
	Seals in motor area defective.	Check motor seals and replace if necessary.	Service







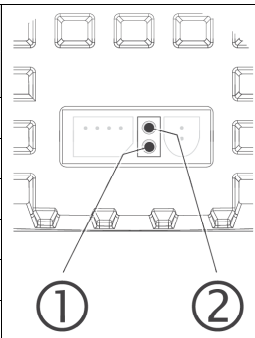



*) Can only be repaired by the operator if the maintenance manual is on hand!

8.1.2 Frequency inverter status indications

LED		Operating status
red ①	green ②	
off	on	Frequency inverter enabled
on	on	Mains switched on and automatic start inhibited
off	slowly blinking	Frequency inverter inhibited
off	fast blinking	Motor parameter identification being executed
fast blinking	off	Undervoltage
slowly blinking	off	Fault active



8.1.3 Fault indication at the keypad

Keypad (PC) ¹⁾	Malfunction	Cause	Remedy	Carried out by
ccr  (71)	System fault	Strong interferences on control cables	Shield control cables	Electrician
		Ground or earth loops in the wiring	Remove ground or earth loops.	
ce1  (62)	Communication fault to CAN-IN1 with Sync control	CAN-IN1 object receives faulty data or communication is interrupted	<ul style="list-style-type: none"> • Check if the bus module is correctly plugged on. • Check transmitter 	Service
ce2  (63)	Communication error to CAN-IN2	CAN-IN2 object receives faulty data or communication is interrupted	<ul style="list-style-type: none"> • Check if the bus module is correctly plugged on. • Check transmitter 	Service
ce3  (64)	Communication error to CAN-IN1 with event or time control	CAN-IN1 object receives faulty data or communication is interrupted	<ul style="list-style-type: none"> • Check if the bus module is correctly plugged on. • Check transmitter 	Service
ce4  (65)	BUS-OFF (many communication errors occurred)	Frequency inverter has received too many incorrect telegrams via the system bus and has been disconnected from the bus	<ul style="list-style-type: none"> • Check if there is a bus termination. • Check shield contact of the cables • Check PE connection Check bus load, if necessary, reduce the baud rate 	Service
ce5  (66)	CAN time-out	For remote parameter setting via system bus (C0370): Slave does not reply. The communication check time has been exceeded	<ul style="list-style-type: none"> • Check system bus wiring • Check system bus configuration 	Service
ce6  (67)	Function module system bus (CAN) attached to the control interface is set to "Warning" or "BUS-OFF"	CAN controller signals "Warning" or "BUS OFF"	<ul style="list-style-type: none"> • Check if there is a bus termination. • Check shield contact of the cables • Check PE connection • Check bus load, if necessary, reduce the baud rate 	Service
ce7  (68)	Communication fault during remote parameter setting via system bus (C0370)	Bus device does respond or is not available	<ul style="list-style-type: none"> • Check if there is a bus termination. • Check shield contact of the cables • Check PE connection • Check bus load, if necessary, reduce the baud rate 	Service
EEr  (91)	External fault	External encoder signals an error (terminal X3/E2 = LOW)	Remove external error. Then reset error EEr by: <ul style="list-style-type: none"> • Mains switching • or X3/E1 = HIGH (TRIP-Reset) 	Operator
ErP0 ... ErP19 	Communication abort between keypad and basic device	Various	Contact manufacturer	
H05  (105)	Internal fault		Contact manufacturer	

Keypad (PC) ¹⁾	Malfunction	Cause	Remedy	Carried out by
LU IMP	DC-bus undervoltage	Mains voltage too low	Check mains voltage	Electrician
		DC-bus voltage too low	Check supply module	
		400 V frequency inverter connected to 230 V mains	Connect frequency inverter to the correct mains voltage.	
OC1 Trip (11)	Short-circuit	Short-circuit	Search for cause of short-circuit; check motor cable.	Operator Electrician
		Excessive capacitive charging current of the motor cable	Use shorter motor cable with lower charging current..	Electrician
OC2 Trip (12)	Earth fault	Grounded motor phase	Check motor, check motor cable	Electrician
		Excessive capacitive charging current of the motor cable	Use shorter motor cable with lower charging current.	
OC3 Trip (13)	Frequency inverter overload during acceleration	Acceleration time too short (C0012)	<ul style="list-style-type: none"> • Increase acceleration time • Check drive dimensioning 	Operator
		U _{min} - boost (C0016) set too large or too small	Correct setting	
		Only for operation with control cabinet inverter 2FCxxx-2NE00	Correct setting	
		U/f- rated frequency (C0015) set too small		
		Differential pressure too high	Check differential pressure of the system.	
		Side channel blower starts at half throttle	<ul style="list-style-type: none"> • Increase acceleration time • Open valves. 	
	Impeller jammed	Repair side channel blower.	Service ^{*)}	
	Short-circuit	Defective motor cable	Check wiring.	Electrician
		Interturn fault in the motor	Check motor.	
OC4 Trip (14)	Frequency inverter overload during deceleration	Deceleration time too short (C0013)	Increase deceleration time.	Operator
		Energy backflow in generator mode operation too high		
OC5 Trip (15)	Frequency inverter overload in stationary operation	Frequent and too long overload	Check dimensioning of side channel blower.	Operator
OC6 Trip (16)	Motor overload (I ² x t - overload)	Motor is thermally overloaded, for instance, because of <ul style="list-style-type: none"> • impermissible continuous current • frequent or too long acceleration processes 	Check dimensioning of side channel blower.	Operator
OH Trip (50)	Heatsink temperature > +85 °C	Ambient temperature too high	Allow frequency inverter to cool down and ensure better ventilation.	Operator
OH Warn	Heatsink temperature > +80 °C	Heatsink strongly polluted	Clean heatsink	
		Impermissibly high currents or frequent and too long accelerations	<ul style="list-style-type: none"> • Check dimensioning of side channel blower.. • Check load, if necessary, replace defective bearings 	Operator Service ^{*)}

Keypad (PC) ¹⁾	Malfunction	Cause	Remedy	Carried out by
OH3 Trip (53)	Temperature monitoring of the motor has been triggered	Motor too hot because of excessive currents or frequent and too long accelerations	Check dimensioning of side channel blower.	Operator
		Impeller jammed	Repair side channel blower.	Service ^{*)}
		PTC or thermostat not connected or defective	Connect or repair PTC or thermostat.	Service
OH4 Trip (54)	Overtemperature frequency inverter	Frequency inverter too hot inside	<ul style="list-style-type: none"> Reduce frequency inverter load. Improve cooling 	Operator
OU IMP	DC-bus overvoltage	Mains voltage too high	Check voltage supply	Electrician
		Braking operation	<ul style="list-style-type: none"> Increase deceleration times. 	Operator
		Earth leakage at motor side	Check motor cable and motor for earth faults. (Separate motor and frequency inverter)	Electrician
Pr5 Trip (79)	Internal fault	Defective EEPROM	Contact manufacturer	

¹⁾ Values in parentheses: error number indicated by the PC parameter setting program (in preparation).
^{*)} Can only be repaired by the operator if the maintenance manual is on hand!

8.1.4 Fault indication reset (TRIP-RESET)

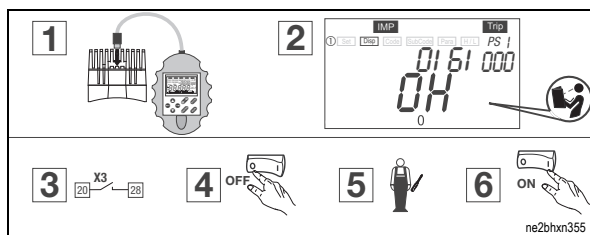

Fig. 26: Fault indication reset (TRIP-RESET)

How to reset the frequency inverter if a fault occurs (TRIP-Reset):

- Connect hand-held keypad to the communication interface during operation.
- Read and take down fault indication on the keypad display.
- Inhibit frequency inverter.
- Disconnect pump-motor unit from the mains.
- Carry out a fault analysis and eliminate the fault.
- Restart the pump-motor unit.

NOTE

The fault indication "EEr" triggered by an external encoder can also be reset via a HIGH-LOW signal at terminal E1 if the fault has been eliminated in advance.

8.2 Service/ after-sales service

Our Service is available for work (in particular the installation of spare parts, as well as maintenance and repair work) not described in these Operating Instructions.

Please observe when returning the pump-motor unit to the manufacturer:

- The pump-motor unit must be delivered complete, i.e. not dismantled.
- The original rating plate of the pump-motor unit must be fixed properly, intact and legible. All warranty claims are voided for pump-motor units delivered for a damage expertise without the original rating plate or with a destroyed original rating plate.
- In case of warranty claims, the manufacturer must be informed of the operating conditions, operating duration etc. and additional detailed information must be provided on request if necessary.
- The pump-motor unit may not present a danger to the workshop personnel.
 - Pump-motor units with contact to hazardous substances must be decontaminated.
 - A declaration of clearance must be provided (📖 48).

8.3 Decontamination and declaration of clearance

 WARNING
<p>Danger from flammable, caustic or toxic substances!</p> <p>To protect the environment and persons, the following applies:</p> <p>Pump-motor units which have come into contact with dangerous substances must always be decontaminated before being passed on to a workshop!</p>

To provide proof that the decontamination was carried out, a declaration of clearance must be included with the pump-motor unit on delivery to the workshop.

The form required for this purpose is available from the manufacturer.

9 Disposal

Have the entire pump–motor unit scrapped by a suitable disposal company:

- Ensure recycling of metals and plastics.
- Assembled PCBs need to be disposed of professionally.

For additional information on disposing of the pump–motor unit, ask the Service Department.

EU declaration of conformity

Manufacturer: Gardner Denver Deutschland GmbH
P.O. Box 1510
D-97605 Bad Neustadt / Saale

Responsible for documentation: Holger Krause
P.O. Box 1510
D-97605 Bad Neustadt / Saale

Designation: G series Side channel blower
G-BH1e, G-BH7e
Types 2BH1...-..N, 2BH7...-..N,
2BH1...-..L, 2BH7...-..L

The side channel blower described above meets the following applicable Community harmonisation legislation:

2004/108/EC Directive 2004/108/EC of the European Parliament and of the Council of 15 December 2004 on the approximation of the laws of the Member States relating to electromagnetic compatibility and repealing Directive 89/336/EEC

2006/42/EC Directive 2006/42/EC of the European Parliament and of the Council of 17 May 2006 on machinery, and amending Directive 95/16/EC

The protection targets of the directive 2006/95/EC have been met

Harmonised standards applied:

EN 1012-1:1996 Compressors and vacuum pumps — Safety requirements — Part 1: Compressors

EN 1012-2:1996 Compressors and vacuum pumps — Safety requirements — Part 2: Vacuum pumps

EN 50178:1197 Electronic equipment for use in power installations

EN 61800-3:2004 Adjustable speed electrical power drive systems —
Part 3: EMC requirements and specific test methods

Bad Neustadt/Saale, 29.12.2009

(Place and date of issue)

ppa. Fred Borschlegl

(Name and function)

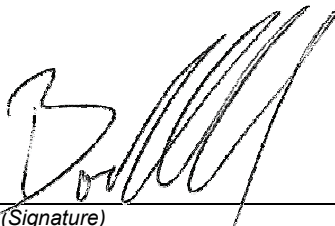

(Signature)

664.44521.40.000



Statement on health safety and on the protection of the environment

- For the safety of our employees and to comply with statutory requirements on handling substances harmful to the health and the environment, this statement must be enclosed, fully completed, with each unit/system sent.
Without the fully completed statement, repair/disposal is not possible and delays are unavoidable!
The statement is to be completed and signed by suitably qualified, authorised personnel at the operating organisation.
In the case of shipment to Germany, the statement is to be completed in German or English.
The statement is to be attached to the outside of the packing on shipment.
If necessary, the carrier is to be informed.

1. Product designation (type):

2. Serial number (no. BN):

3. Reason for sending:

4. The unit/system

- has not come into contact with hazardous substances. There will be no hazards for personnel or the environment during repair/disposal. Continue with "6. Legally binding statement"
has come into contact with hazardous substances. Continue with "5. Information on the contamination"

(if necessary provide more information on an additional sheet)

5. Information on the contamination

The unit/system was used in the following application:

and has come into contact with the following classifiable substances or substances presenting a hazard to health/environment:

Table with 4 columns: Trade name, Chemical designation, Hazardous substance class, Properties (e.g. toxic, inflammable, caustic, radioactive)

- The unit/system has been emptied in accordance with the operating instructions, flushed and cleaned externally.
Safety data sheets in accordance with the applicable regulations are enclosed (..... sheet).
The following safety precautions are necessary for handling (e.g. personal protective equipment):

6. Legally binding statement

I herewith guarantee that the details specified are true and complete and that I, as signatory, am in a position to judge that this is so.
We are aware that we are liable to the contractor for any damages arising from incomplete or incorrect specifications. We are obliged to indemnify the contractor against claims for damages by third parties arising from incomplete or incorrect specifications. We are aware that, irrespective of this statement, we are directly liable to third parties - in particular including the contractor's employees tasked with repair/disposal.

Company/institute:
Name, position: Phone:
Street: Fax:
Post code, city:
Country: Stamp:
Date, signature:



**Elmo
Rietschle**
A Gardner Denver Product

www.gd-elmorietschle.de
er.de@gardnerdenver.com

**Gardner Denver
Schopfheim GmbH**
Roggenbachstraße 58
79650 Schopfheim · Deutschland
Tel. +49 7622 392-0
Fax +49 7622 392-300

**Gardner Denver
Deutschland GmbH**
Industriestraße 26
97616 Bad Neustadt · Deutschland
Tel. +49 9771 6888-0
Fax +49 9771 6888-4000

**Gardner
Denver**

Elmo Rietschle is a brand of
Gardner Denver's Industrial Products
Group and part of Blower Operations.