

WOB-L™



2660/2680 SERIES

MODELS

Standard models

2660CE44

2660CGHI42

2680CE44

2680CGHI42

*Other models based
on availability and
minimum purchase.*

2660CE37

2660CE39

2660CGHI37

2660CGHI39

2680CE37

2680CE39

2680CGHI37

2680CGHI39

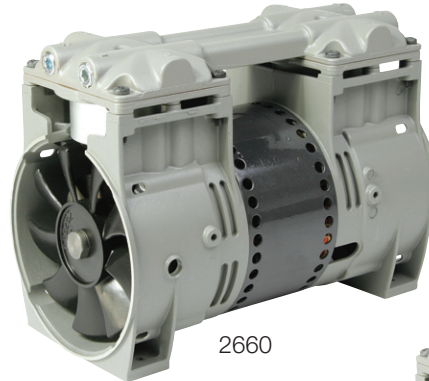

2660



2680

TRIGON®

FEATURES

- Head design allows easily replaced piston seal
- Oil-less, non-lube piston and cylinder
- Permanently lubricated bearings
- Stainless steel valves
- Lightweight die cast aluminum components
- Long-life, high performance piston seal
- Thin wall, hard-coated aluminum cylinder for maximum heat transfer
- Twin fans provide cooling air through and around motor and cylinders
- Dual intake/exhaust manifold system for easy piping
- Balanced for smooth, low vibration operation
- Field service capability
- Inlet filter
- Capacitor
- All wetted aluminum parts treated for corrosion protection from moisture
- Patented one piece head for fewer parts and reduced leak paths
- UL Recognized motor and thermal protector, 115v/60Hz models
- CE/TUV approved, 220-240/50Hz models
(Consult factory for non-standard models)
- Kit options: Guards/Capacitor cover/Cords

Consult factory for custom applications

ISO 9001
CERTIFIED

THOMAS
A Gardner Denver Product

2660 & 2680 Series Performance Data

		Standard					
MODEL NUMBERS		2660CE37 2680CE37		2660CE39 2680CE39		2660CE44 2680CE44	
HEAD CONFIGURATION		Pressure/Vacuum		Pressure/Vacuum		Pressure/Vacuum	
STROKE		.370 Inches		.390 Inches		.440 Inches	
PRESSURE		Flow @ 115v		Flow @ 115v		Flow @ 115v	
CFM @ PSI	LPM @ bar						
PSI	bar	CFM	LPM	CFM	LPM	CFM	LPM
0	0	3.73	105.6	3.92	110.9	4.40	124.5
5	.5	3.65	101.8	3.82	105.9	4.34	121.4
10	1.0	3.53	95.6	3.65	98.5	4.23	114.6
15	1.5	3.36	88.9	3.46	92.1	4.03	107.0
20	2.0	3.20	81.9	3.31	85.7	3.84	100.0
25	3.0	3.03	70.4	3.15		3.67	
30		2.86		3.00		3.50	
35		2.71		2.90			
40		2.58					
MAX. CONTINUOUS PRESSURE		40 PSI	2.8 bar	35 PSI	2.4 bar	30 PSI	2.1 bar
MAX. INTERMITTENT PRESSURE		40 PSI	2.8 bar	35 PSI	2.4 bar	30 PSI	2.1 bar
VACUUM		Flow @ 115v		Flow @ 220v/230v		Flow @ 115v	
CFM @ IN. hg	LPM @ mbar (gauge)						
IN. hg	mbar (gauge)	CFM	LPM	CFM	LPM	CFM	LPM
0	0	3.73	105.6	3.92	110.9	4.40	124.5
5	-100	2.47	84.5	2.62	89.2	2.96	100.5
10	-200	1.86	66.8	1.98	70.9	2.22	80.0
15	-400	1.27	46.6	1.36	49.7	1.52	55.6
20	-600	0.68	26.8	0.72	28.6	0.83	32.4
25	-800	0.11	7.5	0.12	8.0	0.16	9.7
MAX. VACUUM		27.0" hg	-914 mbar	27.0" hg	-914 mbar	27.0" hg	-914 mbar
MAX. AMBIENT AIR TEMP.		104° F	40°C	104° F	40°C	104° F	40°C
MIN. AMBIENT START TEMP.		50° F	10°C	50° F	10°C	50° F	10°C
MAX. RESTART PRESSURE		0 PSI	0 bar	0 PSI	0 bar	0 PSI	0 bar
MAX. RESTART VACUUM		0"hg	0 mbar	0"hg	0 mbar	0"hg	0 mbar
MOTOR VOLTAGE/FREQUENCY		115/60/1		115/60/1		115/60/1	
MOTOR TYPE		Permanent Split Cap.		Permanent Split Cap.		Permanent Split Cap.	
CURRENT AT RATED LOAD (AMPS)		4.5		4.7		5.0	
POWER AT RATED LOAD (WATTS)		480		490		530	
STARTING CURRENT (LOCKED ROTOR, AMPS)		14.6		14.6		14.6	
CAPACITOR VALUE		15 mfd		15 mfd		15 mfd	
MIN. FULL LOAD SPEED (RPM)		1680		1690		1670	
THERMAL PROTECTOR		Yes		Yes		Yes	
NET WEIGHT		14.8 lbs.	6.7 kg	14.8 lbs.	6.7 kg	14.8 lbs.	6.7 kg

The information presented in this material is based on technical data and test results of nominal units. It is believed to be accurate and reliable and is offered as an aid to help in the selection of Thomas products. It is the responsibility of the user to determine the suitability of the product for his intended use and the user assumes all risk and liability whatsoever in connection therewith. Thomas Industries does not warrant, guarantee or assume any obligation or liability in connection with this information.

NOTE: Models pictured are representative of the series and do not represent a specific model number. Consult factory for detailed physical description.

NOTE: 2660 models do not have fan guard or cord standard, these are options. 2680 models include fan guard and cord standard.

2660 & 2680 Series Performance Data

		Standard					
MODEL NUMBERS		2660CGHI37 2680CGHI37		2660CGHI39 2680CGHI39		2660CGHI42 2680CGHI42	
HEAD CONFIGURATION		Pressure/Vacuum		Pressure/Vacuum		Pressure/Vacuum	
STROKE		.370 Inches		.390 Inches		.420 Inches	
PRESSURE		Flow @ 220v/230v/60Hz		Flow @ 220v/230v		Flow @ 220v/230v	
CFM @ PSI	LPM @ bar						
PSI	bar	CFM	LPM	CFM	LPM	CFM	LPM
0	0	3.12 / 3.74	88.3 / 105.9	3.38 / 4.01	95.7 / 113.5	3.59 / 4.30	101.6 / 121.7
5	.5	3.05 / 3.65	85.2 / 102.0	3.30 / 3.92	91.7 / 109.0	3.50 / 4.08	97.5 / 114.5
10	1.0	2.96 / 3.55	80.4 / 96.1	3.17 / 3.77	86.1 / 101.3	3.38 / 4.00	91.8 / 108.4
15	1.5	2.83 / 3.38	75.5 / 90.2	3.03 / 3.56	80.8 / 94.0	3.23 / 3.81	85.7 / 100.2
20	2.0	2.71 / 3.24	70.8 / 84.5	2.90 / 3.38	75.9 / 87.2	3.08 / 3.60	80.0 / 93.4
25	3.0	2.59 / 3.09	60.1 / 71.6	2.77 / 3.21	66.8 / 74.3	2.93 / 3.43	
30		2.48 / 2.96		2.66 / 3.05		2.80 / 3.27	
35		2.33 / 2.77		2.53 / 2.88			
40		2.21 / 2.63		2.43 / 2.73			
MAX. CONTINUOUS PRESSURE		40 PSI	2.8 bar	40 PSI	2.8 bar	30 PSI	2.1 bar
MAX. INTERMITTENT PRESSURE		40 PSI	2.8 bar	40 PSI	2.8 bar	30 PSI	2.1 bar
VACUUM		Flow @ 220v/230v/60Hz		Flow @ 220v/230v		Flow @ 220v/230v	
CFM @ IN. hg	LPM @ mbar (gauge)						
IN. hg	mbar (gauge)	CFM	LPM	CFM	LPM	CFM	LPM
0	0	3.12 / 3.74	88.3 / 105.9	3.38 / 4.01	95.7 / 113.5	3.59 / 4.30	101.6 / 121.7
5	-100	2.17 / 2.54	72.4 / 85.8	2.30 / 2.70	77.6 / 91.6	2.44 / 2.84	81.3 / 94.7
10	-200	1.65 / 1.89	58.7 / 68.5	1.76 / 2.02	62.3 / 72.9	1.83 / 2.13	65.9 / 76.7
15	-400	1.12 / 1.30	41.2 / 47.4	1.20 / 1.39	44.0 / 50.7	1.26 / 1.47	45.9 / 53.5
20	-600	0.61 / 0.69	23.8 / 27.4	0.66 / .75	25.6 / 29.5	0.65 / .81	26.2 / 31.4
25	-800	0.10 / 0.11	6.8 / 7.6	0.11 / .12	7.4 / 8.3	0.11 / .15	7.3 / 9.3
MAX. VACUUM		27.0" hg	-914 mbar	27.0" hg	-914 mbar	27.0" hg	-914 mbar
MAX. AMBIENT AIR TEMP.		104° F	40°C	104° F	40°C	104° F	40°C
MIN. AMBIENT START TEMP.		50° F	10°C	50° F	10°C	50° F	10°C
MAX. RESTART PRESSURE		0 PSI	0 bar	0 PSI	0 bar	0 PSI	0 bar
MAX. RESTART VACUUM		0"hg	0 mbar	0"hg	0 mbar	0"hg	0 mbar
MOTOR VOLTAGE/FREQUENCY		220-240/50/1 - 230/60/1		220-240/50/1 - 230/60/1		220-240/50/1 - 230/60/1	
MOTOR TYPE		Permanent Split Cap.		Permanent Split Cap.		Permanent Split Cap.	
CURRENT AT RATED LOAD (AMPS)		1.9 / 9.2		2.0 / 2.2		1.9 / 2.2	
POWER AT RATED LOAD (WATTS)		425 / 480		435 / 485		405 / 475	
STARTING CURRENT (LOCKED ROTOR, AMPS)		5.8 / 5.6		5.8 / 5.6		5.8 / 5.6	
CAPACITOR VALUE		15 mfd		15 mfd		15 mfd	
MIN. FULL LOAD SPEED (RPM)		1360 / 1640		1360 / 1640		1400 / 1680	
THERMAL PROTECTOR		Yes		Yes		Yes	
NET WEIGHT		15 lbs.	6.8 kg	15 lbs.	6.8 kg	15 lbs.	6.8 kg

Dimensions

2660

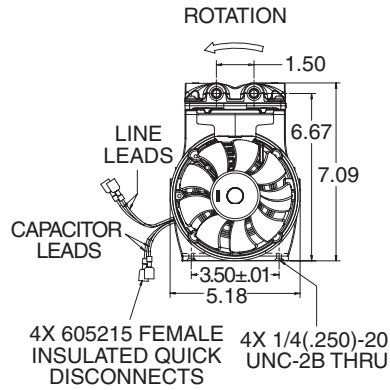
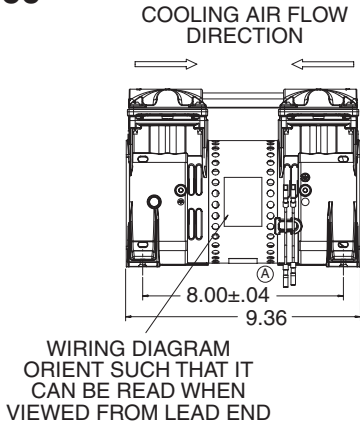

MODEL	A
2668	#8-32 UNC-2B THREAD THRU
2660/2669	1/4-20 UNC-2B THREAD THRU
2680/2689	1/4-20 UNC-2B THREAD THRU

Patent No. 6056521

2680

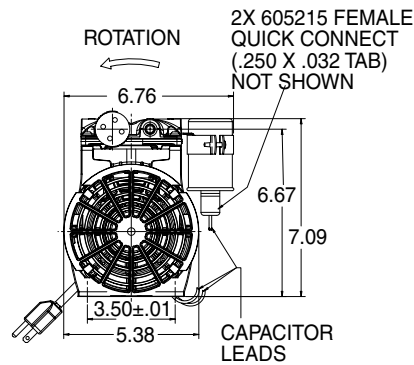
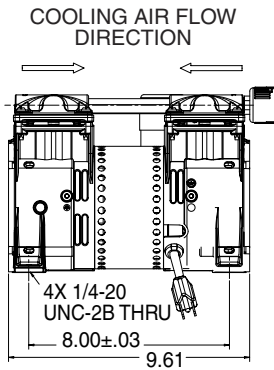

MODEL	A
2668	#8-32 UNC-2B THREAD THRU
2660/2669	1/4-20 UNC-2B THREAD THRU
2680/2689	1/4-20 UNC-2B THREAD THRU

Patent No. 6056521

THOMAS
A Gardner Denver Product

Thomas Products Division
1419 Illinois Ave
Sheboygan, WI 53082 USA
Phone: (920) 457-4891
Fax: (920) 451-4276
www.thomaspumps.com