

## Operating instructions G-BH1, G-BH9

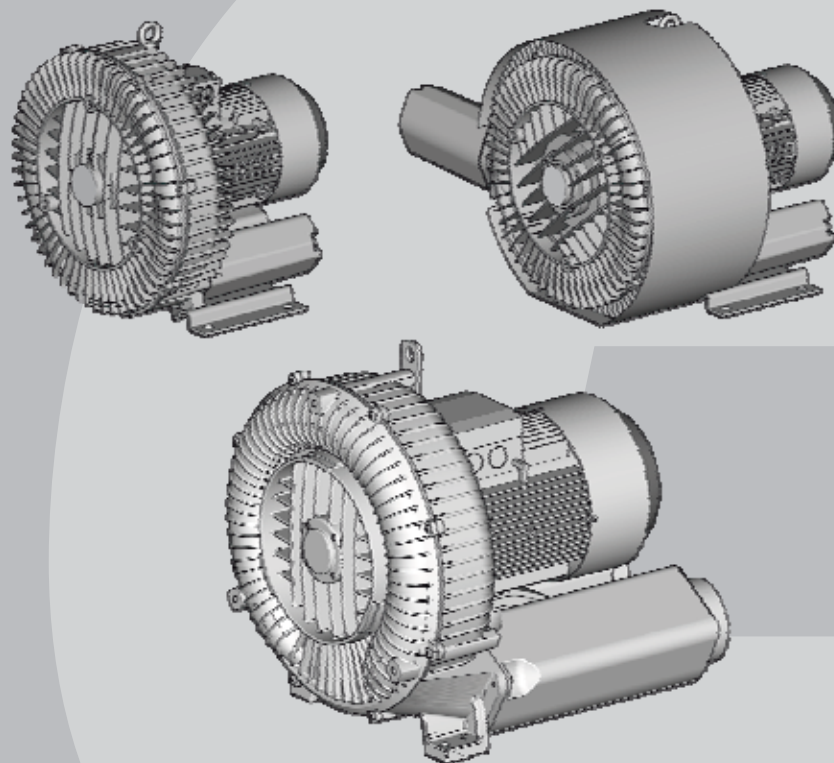

**Elmo  
Rietschle**  
*A Gardner Denver Product*

**CE**



**2BH1 1  
2BH1 2  
2BH1 3  
2BH1 4  
2BH1 5  
2BH1 6  
2BH1 8  
2BH1 9  
2BH9 23**



**G-Serie  
G-Series**  
Seitenkanal  
Side Channel



## Contents

1	Safety .....	3
1.1	Definitions .....	3
1.1.1	Safety alert symbol .....	3
1.1.2	Signal words .....	3
1.2	General safety precautions .....	3
1.3	Residual risks .....	5
2	Intended Use .....	6
3	Technical Data .....	7
3.1	Mechanical data .....	7
3.2	Electrical data .....	11
3.3	Operating conditions .....	11
4	Transport and Handling .....	12
5	Installation .....	13
5.1	Installation .....	14
5.2	Electrical connection (motor) .....	15
5.3	Connecting pipes/hoses (vacuum pump/compressor) .....	18
5.3.1	Inlet connection .....	19
5.3.2	Discharge connection .....	19
5.3.3	Procedure when connecting pipes/hoses .....	20
6	Commissioning .....	21
6.1	Preparation .....	21
6.2	Start-up and shut-down .....	22
7	Operation .....	23
8	Shut-Down and Longer Standstills .....	24
8.1	Preparing for shut-down or longer standstill .....	24
8.2	Storage conditions .....	24
9	Servicing .....	25
9.1	Emptying/Rinsing/Cleaning .....	25
9.2	Repairs/troubleshooting .....	25
9.3	Service/After-sales service .....	27
10	Disposal .....	27
11	Explosion-Protected Design .....	27
	EU declaration of conformity .....	28
	Statement on health safety and on the protection of the environment .....	29

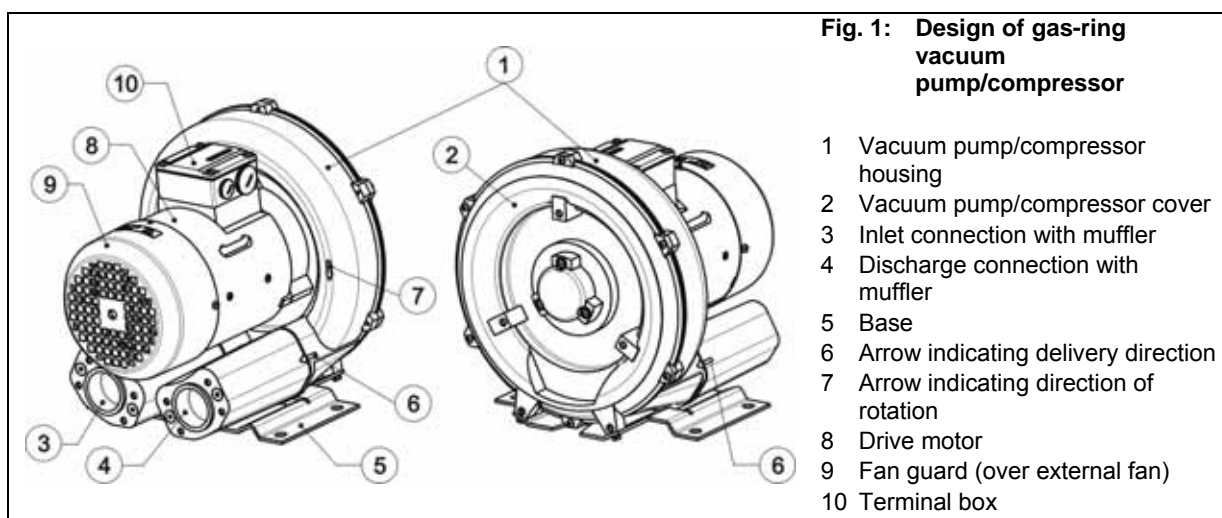

# 1 Safety

## 1.1 Definitions

To point out dangers and important information, the following signal words and symbols are used in these operating instructions:

### 1.1.1 Safety alert symbol

The **safety alert symbol**  is located in the safety precautions in the highlighted heading field on the left next to the signal word (DANGER, WARNING, CAUTION).

Safety precautions **with** a safety alert symbol indicate a danger of **injuries**.

Be sure to follow these safety precautions to protect against **injuries or death!**

Safety precautions **without** a safety alert symbol indicate a danger of **damage**.

### 1.1.2 Signal words

- DANGER** The **signal words** are located in the safety precautions in the highlighted heading field.
- WARNING** They follow a certain hierarchy and indicate (in conjunction with the safety alert symbol, see Chapter 1.1.1) the **seriousness of the danger** and the **type of warning**.
- CAUTION**
- NOTICE**
- NOTE**

See the following explanations:

 <b>DANGER</b>
<p><b>Danger of injuries.</b> Indicates an imminently hazardous situation, that <b>will</b> result in <b>death or serious injury</b> if the corresponding measures are not taken.</p>

 <b>WARNING</b>
<p><b>Danger of injuries.</b> Indicates a potentially hazardous situation, that <b>could</b> result in <b>death or serious injury</b> if the corresponding measures are not taken.</p>

 <b>CAUTION</b>
<p><b>Danger of injuries.</b> Indicates a potentially hazardous situation, that may result in <b>minor or moderate injury</b> if the corresponding measures are not taken.</p>

<b>CAUTION</b>
<p><b>Danger of damage.</b> Indicates a potentially hazardous situation that may result in <b>property damage</b> if the corresponding measures are not taken.</p>

<b>NOTICE</b>
<p>Indicates a possible <b>disadvantage</b>, i.e. undesirable conditions or consequences can occur if the corresponding measures are not taken.</p>

<b>NOTE</b>
<p>Indicates a possible <b>advantage</b> if the corresponding measures are taken; tip.</p>

## 1.2 General safety precautions

 <b>WARNING</b>
<p><b>Improper use of the unit can result in serious or even fatal injuries!</b> These operating instructions</p> <ul style="list-style-type: none"> <li>must have been read completely and understood before beginning any work with or at the pump-motor unit,</li> <li>must be strictly observed,</li> <li>must be available at the operating location of the pump-motor unit.</li> </ul>

 <b>WARNING</b>
<p><b>Improper use of the unit can result in serious or even fatal injuries!</b> Only operate the pump-motor unit</p> <ul style="list-style-type: none"> <li>for the purposes indicated under "Intended Use"!</li> <li>with the fluids indicated under 'Intended Use'!</li> <li>with the values indicated under 'Technical Data'!</li> </ul>

 <b>WARNING</b>
<p><b>Improper use of the unit can result in serious or even fatal injuries!</b> All work on and with the pump-motor unit (transport, installation, operation, shut-down, maintenance, disposal) may only be carried out by <b>trained, reliable expert personnel!</b></p>

**⚠ WARNING**

**When working on the unit, there is a danger of injury, e.g. in the form of cuts/cutting off, crushing and burns!**  
 During all work on and with the pump-motor unit (transport, installation, operation, shut-down, maintenance, disposal) wear **personal safety equipment (safety helmet, protective gloves, safety shoes)!**

**⚠ WARNING**

**Hair and clothing can be pulled into the unit or caught and wound up moving parts!**  
 Do not wear long, loose hair or wide, loose clothes! Use a hair net!

**⚠ DANGER**

**Electrical danger!**  
 Work on electrical installations may be carried out by trained and authorized electricians only!

**⚠ DANGER**

**Electrical danger!**  
 Before beginning work on the unit or system, the following measures must be carried out:

- Deenergize.
- Secure against being switched on again.
- Determine whether deenergized.
- Ground and short-circuit.
- Cover or block off adjacent energized parts.

**⚠ DANGER**

**Electrical danger!**  
 Do not open the motor terminal box until absence of electricity has been ensured!

**⚠ WARNING**

**Danger due to vacuum and gauge pressure: sudden escape of fluids (skin and eye injuries), sudden drawing in of hair and clothing!**  
**Danger due to escaping fluid: Burns!**  
 Use mounting elements, connections, lines, fittings and containers with sufficient freedom from leaks and strength for the pressures which occur.  
 Check the mounting elements, connections, lines, fittings and containers for strength, leaks and firm seating at regular intervals!

**⚠ WARNING**

**Danger from rotating parts (external fan, impeller, shaft):**  
**Cutting/cutting off of extremities, Grasping/winding up of hair and clothing!**  
**Danger due to vacuum and gauge pressure: sudden escape of fluids (skin and eye injuries), sudden drawing in of hair and clothing!**  
**Danger due to escaping fluid: Burns!**  
 Start-up and operation only under the following conditions:

- The pump-motor unit must be completely assembled. When doing so, pay particular attention to the following components:
  - the vacuum pump/compressor cover,
  - the muffler on inlet and discharge connections,
  - the fan guard.
- The pipes/hoses must be connected to inlet and discharge connections.
- Inlet and discharge connections and the connected pipes/hoses may not be closed, clogged or soiled.
- Check the mounting elements, connections of the pipe/hose connections, lines, fittings and containers for strength, leaks and firm seating at regular intervals.

**⚠ WARNING**

**Danger from rotating parts (external fan, impeller, shaft):**  
**Cutting/cutting off of extremities, Grasping/winding up of hair and clothing!**  
**Danger due to vacuum and gauge pressure: sudden escape of fluids (skin and eye injuries), sudden drawing in of hair and clothing!**  
**Danger due to escaping fluid: Burns!**  
 Before beginning work on the pump-motor unit, take the following measures:

- Shut down pump-motor unit and secure against being switched on again.
- Attach a sign on the system controller and on the control elements for the pump-motor unit: "DANGER! Maintenance work on vacuum pump/compressor! Do not switch on!"
- Wait for pump-motor unit to come to a complete stop. Observe run-on time!
- Allow pump-motor unit to cool!
- Shut-off lines. Release pressure.
- Make sure that no vacuum or gauge pressure is present in the lines/tanks to be opened.
- Make sure that no fluids can escape.

**⚠ WARNING**

**Danger from rotating impeller:  
Cutting/cutting of off extremities!**  
The rotating impeller is accessible with the inlet and discharge connections open!  
Do not reach into the unit through open connections!  
Do not insert objects into the unit through the openings!

**⚠ WARNING**

**Danger from rotating impeller:  
Cutting/cutting of off extremities!**  
The rotating impeller is accessible with the inlet and discharge connections open!  
With free entry and exit of gases, i.e. with direct intake out of or direct feeding into the atmosphere without piping, the following therefore applies:  
Provide the inlet and discharge connections of the pump-motor unit either with additional mufflers or with additional piping of a sufficient length to prevent access to the impeller!

**⚠ WARNING**

**Danger of burns from hot surfaces of the pump-motor unit and from hot fluids!**  
High temperatures of up to approx. 160°C [320°F] can occur on the surface of the pump-motor unit.  
Cover the pump-motor unit with a suitable touch protection (e.g. perforated plate cover or wire cover). Do not touch during operation!  
Allow to cool after shut-down!

**1.3 Residual risks**

**⚠ WARNING**

**Danger zone:**  
Hot surface up to approx. 160°C [320°F].  
**Hazard:**  
Possible burns.  
**Protective measures:**  
Cover the pump-motor unit with a suitable touch protection (e.g. perforated plate cover or wire cover).

**⚠ WARNING**

**Danger zone:**  
Fan guard  
**Hazard:**  
Long, loose hair can be drawn into external fan through fan guard grate, even with fan guard mounted!  
**Protective measures:**  
Wear hair net!

**⚠ WARNING**

**Danger zone:**  
Missing or defective muffler inlet or discharge connection.  
**Hazard:**  
Possible serious hearing damage due to emitted noise.  
**Protective measures:**  
Have missing or defective mufflers replaced. Conduct a noise measurement in the system after installing the pump-motor unit. The following measures can be taken from 85 dB(A) and must be taken from 90 dB(A):

- Mark noise area with a warning sign.
- Wear hearing protection.

**⚠ WARNING**

**Danger zone:**  
Environment of pump-motor unit.  
**Hazard:**  
Possible serious hearing damage due to emitted noise.  
**Protective measures:**  
Conduct a noise measurement in the system during operation after installing the pump-motor unit.  
The following measures can be taken from 85 dB(A) and must be taken from 90 dB(A):

- Mark noise area with a warning sign.
- Wear hearing protection.
- With free entry and exit of gases, i.e. with direct intake out of or direct feeding into the atmosphere without piping, attach an additional muffler.

## 2 Intended Use

### This operating manual

- is intended for side channel compressors of the G-BH1 and G-BH9 series, types 2BH1 1 2BH1 2 2BH1 3 2BH1 4 2BH1 5 2BH1 6 2BH1 8 2BH1 9 2BH9 23,
- contains instructions bearing on transport and handling, installation, commissioning, operation, shut-down, storage, servicing and disposal of the G-BH1, G-BH9,
- must be completely read and understood by all operating and servicing personnel before beginning to work with or on the G-BH1, G-BH9,
- must be strictly observed,
- must be available at the site of operation of the G-BH1, G-BH9.

### About the operating and servicing personnel of the G-BH1, G-BH9

- These persons must be trained and authorized for the work to be carried out.
- Work on electrical installations may be carried out by trained and authorized electricians only.

### The G-BH1, G-BH9

- are pump-motor units for generating vacuum or gauge pressure;
- are used to **extract, pump and compress the following gases:**
  - Air,
  - Non-flammable, non-aggressive, non-toxic and non-explosive gases or gas-air mixtures.
  - With differing gases/gas-air mixtures, inquire with the Service Department.
- are equipped with one of the following kind of drive motors:
  - 3-phase AC drive motor with a standard or explosion-protected design
  - Single-phase AC drive motor

These operating instructions apply **only to** pump-motor units with a **standard design**. For an explosion-protected design (EEx e II), see the separate operating instructions.

- are intended for industrial applications,
- are designed for continuous operation. With increased switch-on frequency (6x per hour with equal pauses and operating times) or with increased gas inflow and ambient temperature, the excess temperature limit of the coil and the bearing can be exceeded. Consult the manufacturer when using under such conditions.

When operating the G-BH1, G-BH9 the limits listed in Chapter 3, "Technical Data", Pg. 7 ff. must always be complied with.

### Foreseeable Misuse

It is prohibited

- to use the G-BH1, G-BH9 in applications other than industrial applications unless the necessary protection is provided on the system, e.g. guards suitable for children's fingers;
- to use the device in rooms in which explosive gases can occur if the G-BH1, G-BH9 is not expressly intended for this purpose;
- to extract, to deliver and to compress explosive, flammable, corrosive or toxic fluids, unless the G-BH1, G-BH9 is specifically designed for this purpose;
- to operate the G-BH1 with values other than those specified in Chapter 3, "Technical Data", Pg. 7 ff.

Any unauthorized modifications of the G-BH1, G-BH9 are prohibited for safety reasons.

The operator is only permitted to perform the maintenance and service work described in these operating instructions.

Maintenance and servicing work which goes beyond this may only be carried out by companies which have been authorised by the manufacturer (ask the service department for details).

### 3 Technical Data

#### 3.1 Mechanical data

##### Weight

Single-impeller design		
Type	Weight	
	[kg] approx.	[lbs] approx.
2BH1100-7..0.	9	20
2BH1200-7..0.	9	20
2BH1300-7..0.	9	20
2BH1300-7..1.	10	22
2BH1300-7..2.	11	24
2BH1330-7..0.	10	22
2BH1330-7..1.	11	24
2BH1330-7..2.	12	26
2BH1400-7..0.	13	29
2BH1400-7..1.	16	35
2BH1400-7..2.	17	37
2BH1430-7..0.	14	31
2BH1430-7..1.	17	37
2BH1430-7..2.	18	40
2BH1500-7..0.	20	44
2BH1500-7..1.	22	49
2BH1500-7..2.	23	51
2BH1500-7..3.	25	55
2BH1530-7..0.	21	46
2BH1530-7..1.	23	51
2BH1530-7..2.	24	53
2BH1530-7..3.	26	57
2BH1600-7..0.	27	60
2BH1600-7..1.	30	66
2BH1600-7..2.	36	79
2BH1600-7..3.	40	88
2BH1600-7..6.	32	71
2BH1600-7..7.	39	86
2BH1630-7..0.	29	64
2BH1630-7..1.	32	71
2BH1630-7..2.	37	82
2BH1630-7..3.	43	95
2BH1630-7..6.	34	75
2BH1630-7..7.	40	88

Single-impeller design		
Type	Weight	
	[kg] approx.	[lbs] approx.
2BH180.-7..0.	117	258
2BH180.-7..1.	126	278
2BH180.-7..2.	132	291
2BH183.-7..0.	120	265
2BH183.-7..1.	129	284
2BH183.-7..2.	135	298
2BH190.-7..0.	179	395
2BH190.-7..1.	198	437
2BH190.-7..3.	210	463
2BH193.-7..0.	179	395
2BH193.-7..1.	198	437
2BH193.-7..3.	209	463
2BH923.-...P	167	368
2BH923.-...Q	145	320
2BH923.-...H	151	333

Two-impeller design		
Type	Weight	
	[kg] approx.	[lbs] approx.
2BH1310-7..2.	15	33
2BH1410-7..3.	25	55
2BH1410-7..4.	27	60
2BH1510-7..4.	40	88
2BH1510-7..5.	44	97
2BH1610-7..1.	43	95
2BH1610-7..2.	48	106
2BH1610-7..3.	54	119
2BH1610-7..4.	66	146
2BH1610-7..5.	73	161
2BH1610-7..7.	50	110
2BH1610-7..8.	62	137
2BH1640-7..3.	54	119
2BH1640-7..4.	69	152
2BH1640-7..5.	75	165
2BH1640-7..8.	62	137
2BH181.-7..1.	171	377
2BH181.-7..2.	177	390

Two-impeller design		
Type	Weight	
	[kg] approx.	[lbs] approx.
2BH181-7..3.	203	448
2BH181-7..4.	215	474
2BH184-7..2.	177	390
2BH184-7..3.	203	448
2BH191-7..1.	274	604
2BH191-7..2.	288	635
2BH191-7..3.	299	659
2BH191-7..4.	309	681
2BH1940-7B.2.	275	606
2BH1940-7B.3.	314	692
2BH1940-7B.4.	324	714
2BH1943-7..2.	330	728
2BH1943-7..3.	339	747
2BH1943-7..4.	349	769

**Minimum distances**

Minimum distance to fan guard (for sucking in cooling air):

Type	[mm]	[inches]
2BH1 1.. - 2BH1 4	34	1.34
2BH1 5.. - 2BH1 9	53	2.09
2BH923...	52	2.05

Minimum distance to face of vacuum pump/compressor cover:

Type	[mm]	[inches]
2BH1 1.. - 2BH1 5	20	0.79
2BH1 6..	30	1.18
2BH1 8.. - 2BH1 9	40	1.57
2BH923..	52	2.05

**Noise level**

Measuring-surface sound-pressure level as per EN ISO 3744, measured at a distance of 1 m [3.28 ft] at an operating point of approximately 2/3 of the permissible total pressure difference with the lines connected without a vacuum or pressure relief valve, tolerance ±3 dB (A).

Single-impeller design		
Type	1-m measuring-surface sound pressure level L [dB (A)]	
	50 Hz approx.	60 Hz approx.
2BH1100-7..0.	52	55
2BH1200-7..0.	57	61
2BH1300-7..0.	53	56
2BH1300-7..1.	53	56
2BH1300-7..2.	53	56
2BH1330-7..0.	53	56
2BH1330-7..1.	53	56
2BH1330-7..2.	53	56
2BH1400-7..0.	63	64
2BH1400-7..1.	63	64
2BH1400-7..2.	63	64
2BH1430-7..0.	63	64
2BH1430-7..1.	63	64
2BH1430-7..2.	63	64
2BH1500-7..0.	64	70
2BH1500-7..1.	64	70
2BH1500-7..2.	64	70
2BH1500-7..3.	64	70
2BH1530-7..0.	64	70
2BH1530-7..1.	64	70
2BH1530-7..2.	64	70
2BH1530-7..3.	64	70
2BH1600-7..0.	69	72
2BH1600-7..1.	69	72
2BH1600-7..2.	69	72
2BH1600-7..3.	69	72
2BH1600-7..6.	69	72
2BH1600-7..7.	69	72
2BH1630-7..0.	69	72



Single-impeller design		
Type	1-m measuring-surface sound pressure level L [dB (A)]	
	50 Hz approx.	60 Hz approx.
2BH1630-7..1.	69	72
2BH1630-7..2.	69	72
2BH1630-7..3.	69	72
2BH1630-7..6.	69	72
2BH1630-7..7.	69	72
2BH180.-7..0.	70	74
2BH180.-7..1.	70	74
2BH180.-7..2.	70	74
2BH183.-7..0.	70	74
2BH183.-7..1.	70	74
2BH183.-7..2.	70	74
2BH190.-7..0.	74	79
2BH190.-7..1.	74	79
2BH190.-7..3.	74	79
2BH193.-7..0.	75	80
2BH193.-7..1.	75	80
2BH193.-7..3.	75	80
2BH923..	79	81

Two-impeller design		
Type	1-m measuring-surface sound pressure level L [dB (A)]	
	50 Hz approx.	60 Hz approx.
2BH1310-7..2.	55	61
2BH1410-7..3.	66	69
2BH1410-7..4.	66	69
2BH1510-7..4.	72	74
2BH1510-7..5.	72	74
2BH1610-7..1.	73	76
2BH1610-7..2.	73	76
2BH1610-7..3.	73	76
2BH1610-7..4.	73	76
2BH1610-7..5.	73	76
2BH1610-7..7.	73	76
2BH1610-7..8.	73	76
2BH1640-7..3.	74	78
2BH1640-7..4.	74	78
2BH1640-7..5.	74	78
2BH1640-7..8.	74	---
2BH181.-7..1.	74	---
2BH181.-7..2.	74	78
2BH181.-7..3.	74	78
2BH181.-7..4.	74	78
2BH184.-7..2.	74	78
2BH184.-7..3.	74	78
2BH191.-7..1.	74	84
2BH191.-7..2.	74	84
2BH191.-7..3.	74	84
2BH1940-7B.2.	75	84
2BH1940-7B.3.	75	84
2BH1940-7B.4.	75	84
2BH1943-7..2.	75	84
2BH1943-7..3.	75	84
2BH1943-7..4.	75	84

### Sound power level

Sound power level  $L_w$  as per EN ISO 3744, tolerance  $\pm 3$  dB (A).

Two-impeller design		
Type	Sound power level $L_w$ [dB (A)]	
	50 Hz	60 Hz
2BH191.	-	98
2BH1940	-	98
2BH1943	-	99
2BH923..	-	93

### Tightening torques for screw connections

The following values apply if no other information is available.

With non-electrical connections, property classes of 8.8 and 8 or higher as per ISO 898-1 are assumed.

Tightening torques for non-electrical connections		
Thread	[Nm]	[ft lbs]
M4	2.7 - 3.3	1.99 - 4.44
M5	3.6 - 4.4	2.65 - 3.25
M6	7.2 - 8.8	5.31 - 6.5
M8	21.6 - 26.4	15.9 - 19.5
M10	37.8 - 46.2	27.9 - 34.1
M12	63.0 - 77.0	46.5 - 56.8

The following information for electrical connection applies to all terminal board connections with the exception of terminal strips.

Tightening torques for electrical connections		
Thread	[Nm]	[ft lbs]
M4	0.8 - 1.2	0.59 - 0.89
M5	1.8 - 2.5	1.33 - 1.84

Especially for metal and plastic threaded cable glands and pipe unions, the following values apply:

Tightening torques for metal threaded glands/unions		
Thread	[Nm]	[ft lbs]
M12x1,5	4 - 6	2.95 - 4.43
M16x1,5	5 - 7.5	3.69 - 5.53
M25x1,5	6 - 9	4.43 - 6.64
M32x1,5	8 - 12	5.9 - 8.85
M40x1,5		

Tightening torques for plastic threaded glands/unions		
Thread	[Nm]	[ft lbs]
M12x1,5	2 - 3.5	1.48 - 2.58
M16x1,5	3 - 4	2.21 - 2.95
M25x1,5	4 - 5	2.95 - 3.69
M32x1,5	5 - 7	3.69 - 5.16
M40x1,5		

### 3.2 Electrical data

See rating plate.

### 3.3 Operating conditions

#### Temperatures

Temperature of pumped gases:	max. permissible temperature: +40°C                    [+104°F]  Nominal value: +15°C                    [+59°F]  Pump-motor units for higher fluid temperatures on request.
Ambient temperature:	max. permissible temperature: +40°C                    [+104°F]  min. permissible temperature: -15°C                    [+5°F]  Nominal value: +25°C                    [+77°F]  Ambient temperatures between 25°C [+77°F] and 40°C [+104°F] affect the permissible total pressure difference.  At higher temperatures the winding may be damaged and the grease change interval may be shortened.

#### Installation altitude

Max. of 1,000 m [3,280 ft] above sea level.

When installing the pump-motor unit at an altitude of more than 1,000 m [3,280 ft] above sea level, first inquire with the Service department.

#### Pressures

Min. suction pressure:	See rating plate
Max. discharge pressure in compressor mode:	See rating plate
<p>* The total pressure difference, shown on the rating plate, applies only for the following conditions:</p> <ul style="list-style-type: none"> <li>• Ambient temperature: 25°C</li> <li>• Pressure for vacuum operation: 1013 mbar at pressure connection;</li> <li>• Pressure for compressor operation: 1013 mbar at suction connection;</li> <li>• Intake temperature (temperature of conveyed gases at suction connection): 15°C For ambient temperatures between 25°C and 40°C, the total pressure difference specified on the rating plate must be reduced (at 40°C by 10%).</li> </ul> <p>Consultation with the manufacturer is essential for such operational conditions.</p>	

## 4 Transport and Handling

**⚠ WARNING**

**Tipping or falling can lead to crushing, broken bones etc.! Sharp edges can cause cuts!**  
Wear personal safety equipment (gloves, safety shoes and protective helmet) during transport!

**⚠ WARNING**

**Danger from tipping or falling loads!**  
Prior to transport and handling make sure that all components are securely assembled and secure or remove all components the fasteners of which have been loosened!

### Manual handling:

**⚠ WARNING**

**Danger from lifting heavy loads!**  
Manual handling of the unit is only permitted within the following limits:

- max. 30 kg [max. 66 lbs] for men
- max. 10 kg [max. 22 lbs] for women
- max. 5 kg [max. 11 lbs] for pregnant women

For the weight of the pump-motor unit, see Chapter 3.1, "Mechanical data", Section "Weight", Pg. 7. For weights above the given values use suitable lifting appliances and handling equipment!

### Handling by means of lifting equipment:

**⚠ WARNING**

**Danger from tipping or falling loads!**  
When transporting with lifting equipment, observe the following basic rules:

- Before each transport, check the tight fit of the eye bolt/lifting attachment, see "Tightening torques for screw connections", p. 10.
- The lifting capacity of lifting equipment and lifting gear must be at least equal to the unit's weight. For the weight of the pump-motor unit, see Chapter 3.1, "Mechanical data", Section "Weight", Pg. 7.
- The pump-motor unit must be secured so that it cannot tip or fall.
- Do not stand or walk under suspended loads!

The transport must be carried out in different ways depending on the type:

- 2BH11., 2BH12., 2BH13., 2BH14., 2BH15. (single-impeller): Manual handling
- 2BH15. (two-impeller), 2BH16., 2BH18., 2BH19., 2BH923...  
Transport with crane, hooked onto eye bolt/lifting attachment (1 attachment point)
- 2BH1943:  
Transport with crane, hooked with lifting belts onto eye bolt and onto the holes in the two feet of the vacuum pump/compressor housing (3 attachment points).

For **transport with a crane**, the pump-motor unit can be hooked into the crane hook as follows:

- directly on the eye bolt/lifting attachment (With 2BH194 the eye bolt and the two foot holes should be used)

or possibly

- with lifting belts.

### Eye bolt/lifting attachment:

Types with a weight of up to 30 kg [66 lbs] are **not** equipped with an eye bolt/lifting attachment (2BH11., 2BH12., 2BH13., 2BH14., 2BH15 [single-impeller]).

Types with a weight of more than 30 kg [66 lbs] are equipped with an eye bolt/lifting attachment as **standard** (2BH15. [two-impeller], 2BH16., 2BH18., 2BH19., 2BH9...).

The eye bolt/lifting attachment is mounted on the vacuum pump/compressor housing.

In case of possible removal and remounting of the eye bolt, it must be ensured that the eye level is positioned exactly in the axis direction of the pump-motor unit. Lay shims under the eye bolt if necessary.

The eye bolt/lifting attachment must be firmly tightened.

Loads laterally to the ring level are not permissible. Heavy impact loads during transport must be avoided.

## 5 Installation

### WARNING

#### **Improper use of the unit can result in serious or even fatal injuries!**

Have you read the safety precautions in Chapter 1, "Safety", Pg. 3 f.?

Otherwise you may not carry out any work with or on the pump-motor unit!

### DANGER

#### **Danger from missing view into area of pump-motor unit!**

When operating the control elements without a view into the area of the pump-motor unit, there is a danger that the pump-motor unit will be switched on while other persons are still performing work on it. Extreme injuries are possible!

Provide control elements at a location with a view of the pump-motor unit.

### DANGER

#### **Electrical danger!**

The pump-motor unit must be installed so that the electrical device cannot be damaged by external influences!

In particular, the feed pipes must be securely routed, e.g. in cable ducts, in the floor etc.

### WARNING

#### **Danger from balance damage caused by vibration!**

Vibrating environments can cause balance damage!

Install the pump-motor unit on a solid foundation or on a solid mounting surface.

Check screw glands/unions for mounting the pump-motor unit on the mounting surface regularly for strength and firm seating.

### WARNING

#### **Danger from crushing due to pump-motor unit tipping over!**

Wear personal safety equipment (protective gloves and safety shoes). Handle the unit with the appropriate care. Install the pump-motor unit on a solid foundation or on a solid mounting surface! Check screw glands/unions for mounting the pump-motor unit on the mounting surface regularly for strength.

### WARNING

#### **Danger of fire from flammable substances!**

The pump-motor unit must never come into contact with flammable substances.

### WARNING

#### **Danger of burns from hot surfaces of the pump-motor unit and from hot fluids!**

High temperatures of up to approx. 160°C [320°F] can occur on the surface of the pump-motor unit.

The pump-motor unit must be installed so that accidental touch of its surface is not possible. Cover the pump-motor unit with a suitable touch protection (e.g. perforated plate cover or wire cover).

### WARNING

#### **Danger of injuries from flying parts!**

Select installation so that parts that are thrown out through the grate if the external fan breaks cannot hit persons!

### CAUTION

#### **Danger of tripping and falling!**

Make sure the unit does not present a danger of tripping. Lay cables and pipes so that they cannot be reached during operation (recessed in floor, in ducts on the wall etc.).

### CAUTION

#### **Danger of overheating due to hot surface of pump-motor unit!**

High temperatures can occur on the surface of the pump-motor unit.

Temperature sensitive parts, such as lines or electronic components, may not come into contact with the surface of the pump-motor unit.

The pump-motor unit is ready to connect on delivery. However, if the time from delivery to commissioning of the pump-motor unit exceeds a certain period, the lubrication of the rolling bearings must be renewed.

See Chapter 8.2, "Storage conditions", Section "Lubrication of rolling bearings after longer storage", Pg. 24 for information on this topic.

Carry out the following work to install the pump-motor unit:

- Installation and securing,
- Attachment of the included loose muffler if necessary,
- Attachment of threaded flange or hose flange (available as accessories) for the connection of inlet or discharge pipe to the muffler,
- Electrical connection,
- Connection of inlet and discharge connection to the system.

## 5.1 Installation

### WARNING

For an installation that differs from the following specifications, it is necessary to inquire with the Service Department!

#### Ambient conditions:

The pump-motor unit is suitable for installation in the following environments:

- In a dusty or damp environment,
  - in buildings,
  - in the open.
- When properly installed in the open, the pump-motor unit must be protected from exposure to intensive sunlight, e.g. by attaching a protective roof. Otherwise, no special protective devices against the effects of weathering are required.

The drive motors of the pump-motor units have the following design:

- with degree of protection IP55 (see rating plate),
- with tropicalized insulation.

#### Installation conditions:

The pump-motor unit must be installed as follows:

- on level surfaces,
  - at a maximum height of 1000 m [3280 ft] above sea level.
- When installing at an altitude of more than 1,000 m [3,280 ft] above sea level, first inquire with the Service Department.

#### Minimum distances:

To ensure sufficient cooling of the pump-motor unit, it is absolutely necessary that the required minimum distances to the **fan guard** and to the **face of the vacuum pump/compressor cover** be maintained. see Chapter 3.1, "Mechanical data", Section "Minimum distances", Pg. 8.

The minimum distances to the face of the vacuum pump/compressor cover are especially important when installing on the vacuum pump/compressor cover or near a wall.

### CAUTION

To ensure sufficient cooling of the pump-motor unit, also observe the following:

- Ventilation screens and openings must remain clear.
- Discharge air of other units may not be directly sucked in again!

#### Noise radiation:

To reduce the noise radiation, the following must be observed:

- Do not mount pump-motor unit on noise-conducting or noise-radiating parts (e.g. thin walls or sheet-metal plates).
- Provide pump-motor unit with sound-insulating intermediate layers (e.g. rubber buffers under the base of the pump-motor unit) if necessary.
- Install the pump-motor unit on a stable foundation or on a rigid mounting surface. This provides for smooth, low-vibration running of the pump-motor unit.

Components for reducing noise on the pump-motor unit:

- **Mufflers** (included as standard equipment): On delivery the pump-motor units are equipped with attached mufflers as standard. The noise radiation is considerably reduced by the mufflers. See Fig. 2 to Fig. 9, Pg. 18 ff.
- **Additional silencer** (available as an accessory for the 2BH1): The additional mufflers enable a further noise reduction. They may only be used with free entry and exit of gases, i.e. with direct intake out of or direct feeding into the atmosphere **without piping**.

- **Sound protection hood** (available as an accessory for the 2BH1):  
Noise protection hoods are suitable for installation in rooms and in the open. They reduce both the total sound pressure level and tonal components that are perceived as particularly annoying.

#### Installation variants/axis position:

Basically, when installing the pump-motor unit, the following variants are possible with a different axis position (horizontal or vertical):

- Horizontal installation
- Vertical installation on the vacuum pump/compressor cover ("cover installation")
- Vertical mounting on the wall

Basically, all variants are possible with all type.

#### Exceptions

- For the 2BH1943, vertical axis mounting on the compressor cover ("cover position") is necessary.
- For the 2BH923, only horizontal axis mounting and vertical axis mounting on the compressor cover are possible.
- For units with condensate water opening, horizontal axis mounting with a foot below is necessary.

#### Horizontal axis mounting

The foot of the unit has fastening holes.

- Screw the foot of the unit to the base using suitable screws.  
**All fastening holes must have screws!**

#### Vertical axis mounting on the compressor cover ("cover position")

For vertical axis mounting on the compressor cover, use spring elements.

Spring elements are available as accessories and come in a set of 3. The upper part has a threaded stud and the lower part a threaded hole.

- Fastening spring elements to the unit:  
Screw threaded studs of the spring elements into the holes on the front side of the compressor cover and tighten.
- Fastening the unit with spring elements to the foundation:  
Select suitable fastening elements for the threaded hole.  
Screw spring elements over the threaded hole into the base or foundation.

#### Vertical axis mounting on the wall with the compressor cover pointing downward

For vertical axis mounting of the unit on the wall, the unit is fastened using the holes in the foot. The foot of the unit has fastening holes.

- Place the unit with the foot to the wall on a base plate with sufficient load-bearing capability in the mounting position.
- Screw the foot of the unit to the wall using suitable screws.  
**All fastening holes must have screws!**
- Remove the base plate.

#### Eye bolt/lifting attachment:

After set-up, the eye bolt/lifting attachment can be removed.

## 5.2 Electrical connection (motor)

### DANGER

#### Electrical danger!

Malpractice can result in severe injuries and material damage!

### DANGER

#### Electrical danger!

The electrical connection may be carried out by trained and authorized electricians only!

### DANGER

#### Electrical danger!

Before beginning work on the unit or system, the following measures must be carried out:

- Deenergize.
- Secure against being switched on again.
- Determine whether deenergized.
- Ground and short-circuit.
- Cover or block off adjacent energized parts.

### CAUTION

Incorrect connection of the motor can lead to serious damage to the unit!

#### Regulations:

The electrical connection must be carried out as follows:

- according to the applicable national and local laws and regulations,
- according to the applicable system-dependent prescriptions and requirements,
- according to the applicable regulations of the utility company.

**Electrical power supply:**

Observe the **rating plate**.

It is imperative that the operating conditions correspond to the data given on the rating plate!

Deviations permissible without reduction in performance:

- ±5 % voltage deviation
- ±2 % frequency deviation

**Connection to drive-motor terminal box:**

Open the required cable entry openings on the terminal box. Here the following two cases are differentiated:

- The cable entry opening is prefabricated and provided with a sealing plug.
- Screw out sealing plug.

OR

- The cable entry opening is closed off with a casting skin (only on pump-motor units with drive-motor axis heights of 100 to 160 in standard design).
- Break out casting skin using a suitable tool. For example, use a metal pin with a corresponding diameter or a chisel and hammer.

<b>CAUTION</b>
<p>When pounding out the casting skin on the cable entry openings in the terminal box, the terminal box or its parts can be damaged (e.g. terminal board, cable connections).</p> <p>Proceed with suitable caution and precision when doing so! Prevent flash formation!</p>

Mount cable glands on the terminal box. Proceed as follows:

- Select one cable gland in each case which is suitable for the cable diameter.
- Insert this cable gland in the opening of the terminal box.  
Use a reducer if necessary.
- Screw on the cable gland so that no moisture, dirt etc. can penetrate into the terminal box.

Carry out the connection and the arrangement of the jumpers in accordance with the **circuit diagram in the terminal box**.

Connect the protective conductor to the terminal with the following symbol:



The electrical connection must be carried out as follows:

- The electrical connection must be permanently safe.
- There may be no protruding wire ends.
- Clearance between bare live parts and between bare live parts and ground:  $\geq 5.5 \text{ mm}$  [0.217"] (at a nominal voltage of  $U_N \leq 690\text{V}$ ).
- For the tightening torques for terminal board connections (except terminal strips), see Chapter 3.1, "Mechanical data", Section "Tightening torques for screw connections", Pg. 10.
- For terminals with clamping straps (e.g. as per DIN 46282), the conductors must be inserted so that approximately the same clamping height results on both sides of the bar. Individual conductors must therefore be bent into a U-shape or connected with a cable lug (DIN 46234).

This also applies to:

- the protective conductor,
- the outer ground conductor.

Both conductors can be recognized from their color (green/yellow).

<b>⚠ DANGER</b>
<p><b>Electrical danger!</b></p> <p>The terminal box must be free from</p> <ul style="list-style-type: none"> <li>• foreign bodies,</li> <li>• dirt,</li> <li>• humidity.</li> </ul> <p>Terminal box cover and cable entries must be tightly closed so as to make them dustproof and waterproof. Check for tightness at regular intervals.</p>

<b>⚠ DANGER</b>
<p><b>Electrical danger!</b></p> <p>Clearance between bare live parts and between bare live parts and ground:</p> <p>at least <b>5.5 mm [0.217"]</b> (at a nominal voltage of <math>U_N \leq 690\text{V}</math>).</p> <p>There may be no protruding wire ends!</p>



**For motor overload protection:**

- Use motor circuit breakers.
- This must be adjusted to the specified nominal current (see rating plate).

 <b>DANGER</b>
<p><b>Electrical danger!</b> There is danger of an electrical shock when a defective pump-motor unit is touched! Mount motor circuit breaker. Have electrical equipment checked regularly by an electrician.</p>

**Interference immunity of drive motor:**

For drive motors with integrated sensors, the operator must provide for a sufficient interference immunity itself. Select a suitable sensor signal cable (e.g. with screening, connection as for a motor power-supply cable) and analyzing unit.

**Operation with frequency converter:**

 <b>WARNING</b>
<p>Pump-motor units with a UL approbation may not be operated on frequency converters in the US without testing by a suitable test agency!</p>

With a power supply by a frequency converter, the following must be observed:

- High-frequency current and voltage harmonics in the motor supply cables can lead to emitted electromagnetic interference. This is dependent on the converter design (type, manufacturer, interference suppression measures).
- Be sure to observe the EMC notes of the converter manufacturer!
- Use screened power supply cables if necessary. For optimal screening, the screen must be conductively connected over a large area to the metal terminal box of the drive motor with a screwed metal gland.
- In the case of drive motors with integrated sensors (e.g. PTC thermistors) interference voltage can occur on the sensor cable depending on the converter type.
- Limit speed:  
see specifications on the rating plate.

### 5.3 Connecting pipes/hoses (vacuum pump/compressor)

#### Mufflers:

The pump-motor units are delivered with mufflers (indicated with arrows in the following illustrations) for the inlet and discharge connections as standard equipment.

On delivery the mufflers are already mounted on the following pump-motor units.

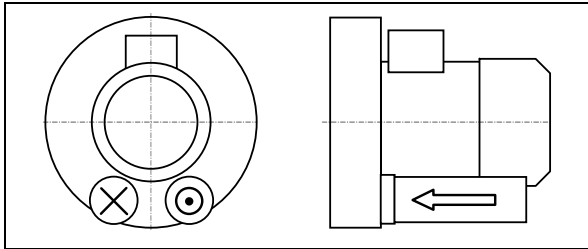

Fig. 2: 2BH1... (single-impeller pump-motor units), 2BH9 23

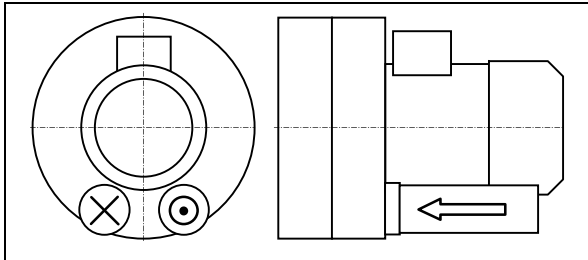

Fig. 3: 2BH1640 (two-impeller pump-motor unit with double-flow design)

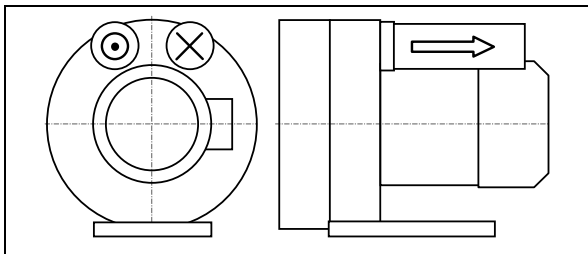

Fig. 4: 2BH1840-7G... (two-impeller pump-motor unit with double-flow design)

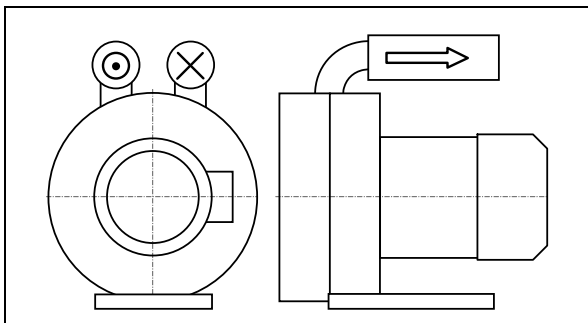

Fig. 5: 2BH1840-7J... (two-impeller pump-motor unit with double-flow design)

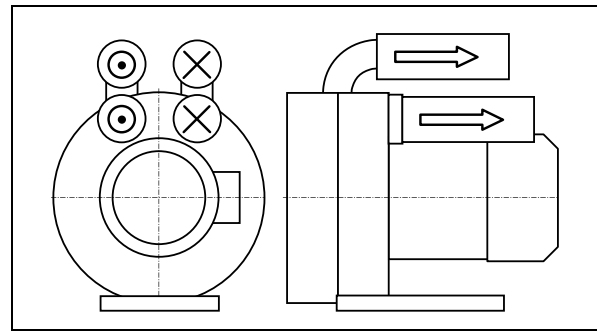

Fig. 6: 2BH1840-7L... (two-impeller pump-motor unit with double-flow design)

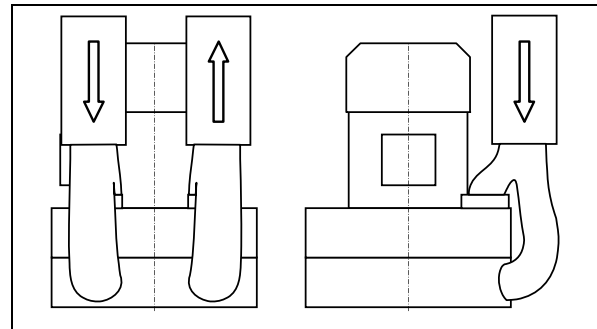

Fig. 7: 2BH1943 (two-impeller pump-motor unit with double-flow design)

On two-impeller pump-motor units with a two-stage design of the types 2BH1310 to 2BH1910 the discharge-side muffler is included loose for packing-related reasons and must be mounted by the customer.

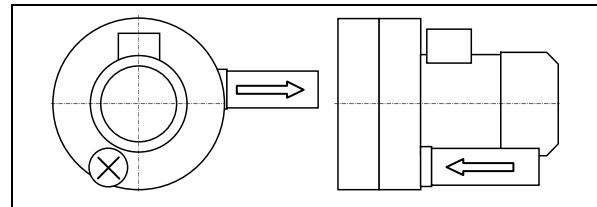

Fig. 8: 2BH1310 ... 2BH1610, 2BH1910 (two-impeller pump-motor units with a two-stage design)

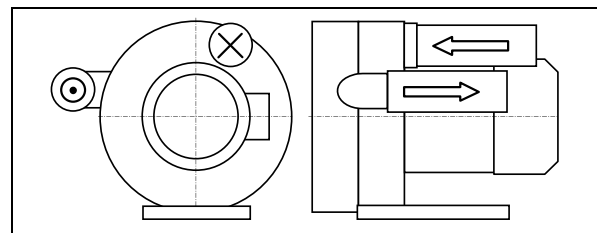

Fig. 9: 2BH1810 (two-impeller pump-motor unit with a two-stage design)

**⚠ WARNING****Danger from rotating impeller:  
Cutting/cutting of off extremities!**

The rotating impeller is accessible with the inlet and discharge connections open!

With free entry and exit of gases, i.e. with direct intake out of or direct feeding into the atmosphere without piping, the following therefore applies:

Provide the inlet and discharge connections of the pump-motor unit either with additional mufflers or with additional piping of a sufficient length to prevent access to the impeller!

**Connections:**

To prevent foreign bodies from entering the unit, all connections are sealed off when delivered. Do not remove the sealing plugs until immediately before connecting the pipes/hoses.

The following applies for the arrangement of the pipe/hose connections:

The **pumped gases** are sucked in via the inlet connection (see Chapter 5.3.1, Pg. 19) and discharged via the discharge connection (see Chapter 5.3.2, Pg. 19).

The **shaft rotating direction** is marked with an arrow on the back of the vacuum pump/compressor housing (Fig. 1, Pg. 2, Item 7).

The **delivery direction of the gases** is marked with arrows on both connections (Fig. 1, Pg. 2, Item 6).

**⚠ WARNING****Danger from interchanging inlet and pressure line!**

Interchanged inlet and pressure lines can lead to damage to the pump-motor unit and the system, and as a result of this to serious injuries!

Make sure that the inlet and pressure line cannot be confused when connecting.

Look for the clear marking with the arrow indicating the delivery direction on the inlet and discharge connections.

**⚠ WARNING****Danger due to vacuum and gauge pressure!****Danger due to escaping fluid!**

During operation, connected pipes and vessels are vacuumized or pressurized!

Use only mounting elements, connections, lines, fittings and containers with sufficient freedom from leaks and strength for the pressures which occur.

Make sure that the mounting elements and connections are mounted sufficiently firmly and leak-free!

**CAUTION**

If the pumped gases are passed on on the discharge side in a closed pipe system, then it must be ensured that the pipe system is adapted to the maximum discharge pressure. See Chapter 3.3: "Operating conditions", Section "Pressures", Pg. 11. Connect a pressure relief valve upstream if necessary.

**NOTICE**

Attach pipes/hoses free of mechanical tensions. Support the weight of the pipes/hoses.

**5.3.1 Inlet connection**

The inlet connection with the related muffler (Fig. 1, Pg. 2, Item 3) is marked with an arrow pointing into the vacuum pump/compressor. Connect the inlet pipe here. The pumped gases are sucked in via this.

Procedure: see Chapter 5.3.3.

**⚠ WARNING****Danger from solid bodies and impurities in the pump-motor unit!**

If solid bodies penetrate into the pump-motor unit, blades of the impellers can break and broken pieces can be thrown out.

Install a filter in the inlet pipe.  
Replace filter regularly!

**5.3.2 Discharge connection**

The discharge connection with the related muffler (Fig. 1, Pg. 2, Item 4) is marked with an arrow pointing out of the vacuum pump/compressor. Connect the discharge pipe here. The pumped gases are discharged via this. Procedure: see Chapter 5.3.3.

### **5.3.3 Procedure when connecting pipes/hoses**

Attach the pipes/hoses to the unit as described in the following. The pipes/hoses are connected differently to inlet and discharge connections depending on the muffler design and the type of line (pipe or hose):

- Muffler with inside threads:  
The pipe is screwed directly into the muffler.
- Muffler without inside thread:
  - Screw threaded flange (available as an accessory) onto the muffler.
  - Screw the pipe into the threaded flange.
- Hose connection:
  - for 2BH1 Screw the hose flange (available as an accessory) onto the silencer.
  - Push the hose onto the hose flange and secure it with a hose clamp. See Chapter 3.1, "Mechanical data", Section "Tightening torques for screw connections", Pg. 10 for information on this topic.

## 6 Commissioning

### WARNING

**Improper use of the unit can result in serious or even fatal injuries!**

Have you read the safety precautions in Chapter 1, "Safety", Pg. 3 f.? Otherwise you may not carry out any work with or on the pump-motor unit!

### WARNING

**Danger from rotating parts (external fan, impeller, shaft): Cutting/cutting off of extremities, Grasping/winding up of hair and clothing!**

**Danger due to vacuum and gauge pressure: sudden escape of fluids (skin and eye injuries), sudden drawing in of hair and clothing!**

**Danger due to escaping fluid: Burns!**

Start-up and operation only under the following conditions:

- The pump-motor unit must be completely assembled. When doing so, pay particular attention to the following components:
  - the vacuum pump/compressor cover,
  - the muffler on inlet and discharge connections,
  - the fan guard.
- The pipes/hoses must be connected to inlet and discharge connections.
- Inlet and discharge connections and the connected pipes/hoses may not be closed, clogged or soiled.
- Check the mounting elements, connections of the pipe/hose connections, lines, fittings and containers for strength, leaks and firm seating at regular intervals.

## 6.1 Preparation

### WARNING

**Danger from closed connections!**

With closed/soiled intake or discharge connections vacuum or gauge pressure results in the pump-motor unit.

This can overheat and damage the drive motor winding.

Before start-up, make sure that the inlet and discharge connections are not closed, clogged or soiled!

### CAUTION

Before starting up again after a longer standstill: Measure the insulation resistance of the motor. With values  $\leq 1 \text{ k}\Omega$  per volt of nominal voltage, the winding is too dry.

#### Measures before start-up:

- If a shut-off device is installed in the discharge pipe: Make sure that the unit is NOT operated with the shut-off device closed.
- Before starting up the pump-motor unit, observe the values specified on the rating plate. Specifications on the drive-motor nominal current apply at a gas entry and ambient temperature of  $+40^\circ \text{C}$  [ $104^\circ \text{F}$ ].
- Adjust the motor circuit breaker to the drive-motor nominal current.

#### Check direction of rotation:

- The intended rotating direction of the shaft is marked with arrows on the vacuum pump/compressor housing (Fig. 1, Pg. 2, Item. 7).
- The gas delivery direction is marked with arrows on the inlet and discharge connections (Fig. 1, Pg. 2, Item 6).
- Make sure the pipes/hoses on the inlet and discharge connections are properly connected.
- Switch the pump-motor unit on briefly and then off again.
- Compare the actual rotating direction of the external fan with the intended shaft rotating direction indicated with the arrows shortly before the pump-motor unit comes to a standstill.
- If necessary, reverse the direction of rotation of the motor.

**⚠ WARNING**

**Danger due to rotating parts! Danger due to vacuum and gauge pressure! Danger due to escaping fluid!**

Test runs may also only be conducted with the pump-motor unit completely mounted.

**⚠ DANGER**

**Electrical danger!**

The electrical connection may be carried out by trained and authorized electricians only!

**⚠ DANGER**

**Electrical danger!**

Before beginning work on the unit or system, the following measures must be carried out:

- Deenergize.
- Secure against being switched on again.
- Determine whether deenergized.
- Ground and short-circuit.
- Cover or block off adjacent energized parts.

**Check operating speeds:**

Observe the operating speed specified on the rating plate. This may not be exceeded, as otherwise the noise radiation, vibration behavior, grease consumption duration and bearing change interval worsen. To prevent damage as a result of higher speeds, it may be necessary to inquire with the Service Department as to the maximum speed.

**⚠ WARNING**

**Danger of hearing damage due to noise radiation!**

For the noise emission of the pump-motor unit measured by the manufacturer, see Chapter 3.1, "Mechanical data", Section "Noise level", Pg. 8. However, the actual noise emission during operation is highly dependent on the installation and system conditions. Conduct a noise measurement in the system during operation after installing the pump-motor unit. The following measures can be taken from 85 dB(A) and must be taken from 90 dB(A):

- Mark noise area with a warning sign.
- Wear hearing protection.
- With free entry and exit of gases, i.e. with direct intake out of or direct feeding into the atmosphere without piping, attach an additional muffler.

**6.2 Start-up and shut-down****Start-up**

- Open shut-off device in intake/discharge pipe.
- Switch on power supply for drive motor.

**Shut-down:**

- Switch off power supply for drive motor.
- Close shut-off device in intake/discharge pipe.

## 7 Operation

<b>⚠ WARNING</b>
<p><b>Improper use of the unit can result in serious or even fatal injuries!</b></p> <p>Have you read the safety precautions in Chapter 1, "Safety", Pg. 3 f.?</p> <p>Otherwise you may not carry out any work with or on the pump-motor unit!</p> <p>Also <b>be sure</b> to read the safety precautions in Chapter 6, "Commissioning", Pg. 21!</p>

<b>CAUTION</b>
<p><b>Danger of bearing damage!</b></p> <p>Heavy mechanical impacts must be avoided during operating and while at a standstill.</p>

### Starting up and shutting down

See Chapter 6, "Commissioning", Sub-Chapter 6.2, "Start-up and shut-down", Pg. 22.

Also be sure to observe the following important notes especially for operation:

<b>⚠ WARNING</b>
<p><b>Danger of burns from hot surfaces of the pump-motor unit and from hot fluids!</b></p> <p>High temperatures of up to approx. 160°C [320°F] can occur on the surface of the pump-motor unit.</p> <p>Do not touch during operation!</p> <p>Allow to cool after shut-down!</p>

<b>CAUTION</b>
<p><b>Danger of overheating due to hot surface of pump-motor unit!</b></p> <p>High temperatures of up to approx. 160°C [320°F] can occur on the surface of the pump-motor unit.</p> <p>Temperature sensitive parts, such as lines or electronic components, may not come into contact with the surface of the pump-motor unit.</p>

<b>CAUTION</b>
<p><b>Danger of overheating!</b></p> <p>During operation the standstill heating may, if installed, <b>not</b> be switched on!</p>

<b>CAUTION</b>
<p><b>Danger of rusting due to collection of condensed water in drive motor area!</b></p> <p>On drive motors with closed condensed water openings:</p> <p>Remove closures occasionally to allow any water which has collected to drain off.</p>

## 8 Shut-Down and Longer Standstills

### 8.1 Preparing for shut-down or longer standstill

<b>⚠ WARNING</b>
<p><b>Improper use of the unit can result in serious or even fatal injuries!</b></p> <p>Have you read the safety precautions in Chapter 1, "Safety", Pg. 3 f.?</p> <p>Otherwise you may not carry out any work with or on the pump-motor unit!</p>

<b>CAUTION</b>
<p><b>Danger of rusting due to collection of condensed water in drive motor area!</b></p> <p>On drive motors with closed condensed water openings:</p> <p>Remove closures occasionally to allow any water which has collected to drain off.</p>

<b>CAUTION</b>
<p><b>Danger of bearing damage!</b></p> <p>Avoid mechanical shocks during operation and shut-down.</p>

Prior to shut-down or longer standstill, proceed as follows:

- Switch off the pump-motor unit.
- Close shut-off device in inlet and pressure line if installed.
- Disconnect pump-motor unit from power supply.
- Release pressure.  
When doing so, open pipes/hoses slowly and carefully so that the vacuum or gauge pressure in the pump-motor unit can be released.
- Remove pipes/hoses.
- Provide mufflers on inlet and discharge side with sealing plugs.

### 8.2 Storage conditions

To prevent standstill damage during storage, the environment must provide the following conditions:

- dry,
- dust-free,
- low-vibration ( $V_{\text{eff}} \leq 2.8 \text{ mm/s}$  [0.11"/sec]).
- Ambient temperature:  
min.  $-30^{\circ}\text{C}$  [ $-22^{\circ}\text{F}$ ]  
max.  $40^{\circ}\text{C}$  [ $+104^{\circ}\text{F}$ ].

<b>CAUTION</b>
<p><b>Danger of overheating due to high temperature!</b></p> <p>When storing in an environment with a temperature of over <math>40^{\circ}\text{C}</math> [<math>104^{\circ}\text{F}</math>], the winding may be damaged and the grease change interval may be shortened.</p>

#### Lubrication of rolling bearings after longer storage:

The new pump-motor unit may at first be stored following delivery. If the time from deliver to commissioning exceeds the following periods, the lubrication of the rolling bearings must be renewed:

- Under advantageous storage conditions (as specified above): 4 years.
- Under disadvantageous storage conditions (e.g. high humidity, salty air, sandy or dusty air): 2 years.

In these cases open rolling bearings must be relubricated and closed rolling bearings must be completely replaced. In this case be sure to inquire with the Service Department. In particular, exact information with regard to the procedure and grease type are required.

<b>⚠ WARNING</b>
<p><b>Improper use of the unit can result in serious or even fatal injuries!</b></p> <p>All maintenance work on the pump-motor unit must always be performed by the Service Department!</p> <p>Maintenance work on the pump-motor unit may only be conducted by the operator itself when the related <b>maintenance manual</b> on hand!</p> <p>Inquire with the Service Department!</p>

#### Commissioning after longer standstill:

Before recommissioning after a longer standstill, measure the insulation resistance of the drive motor. With values  $\leq 1 \text{ k}\Omega$  per volt of nominal voltage, the winding is too dry.



## 9 Servicing

<b>⚠ WARNING</b>
<p><b>Improper use of the unit can result in serious or even fatal injuries!</b></p> <p>Have you read the safety precautions in Chapter 1, "Safety", Pg. 3 f.?</p> <p>Otherwise you may not carry out any work with or on the pump-motor unit!</p>

<b>⚠ WARNING</b>
<p><b>Improper use of the unit can result in serious or even fatal injuries!</b></p> <p>All maintenance work on the pump-motor unit must always be performed by the Service Department!</p> <p>Maintenance work on the pump-motor unit may only be conducted by the operator itself when the related <b>maintenance manual</b> on hand!</p> <p>Inquire with the Service Department!</p>

### 9.1 Emptying/Rinsing/Cleaning

Before any maintenance/servicing work, empty, rinse and clean the outside of the unit.

- Empty unit with air and rinse until all residues have been removed.
- Clean the outside of the unit with compressed air.
  - Wear gloves and protective safety glasses.
  - Secure the surrounding area.
  - Clean the entire surface of the unit and exterior fan with compressed air.

### 9.2 Repairs/troubleshooting

Fault	Cause	Remedy	Carried out by
Motor does not start; no motor noise.	At least two power supply leads interrupted.	Eliminate interruption by fuses, terminals or power supply cables.	Electrician
Motor does not start; humming noise..	One power supply lead interrupted.	Eliminate interruption by fuses, terminals or power supply cables.	Electrician
	Impeller is jammed.	Open vacuum pump/compressor cover, remove foreign body, clean.	Service <sup>*)</sup>
		Check or correct impeller gap setting if necessary.	Service
	Impeller defective.	Replace impeller.	Service <sup>*)</sup>
	Rolling bearing on drive motor side or vacuum pump/compressor side defective.	Replace motor bearing or vacuum pump/compressor bearing.	Service <sup>*)</sup>
Protective motor switch trips when motor is switched on. Power consumption too high.	Winding short-circuit.	Have winding checked.	Electrician
	Motor overloaded. Throttling does not match specification on rating plate.	Reduce throttling.	Service <sup>*)</sup>
		Clean filters, mufflers and connection pipes if necessary.	Service <sup>*)</sup>
	Compressor is jammed.	See fault: "Motor does not start; humming noise." with cause: "Impeller is jammed."	Service <sup>*)</sup>

<b>Fault</b>	<b>Cause</b>	<b>Remedy</b>	<b>Carried out by</b>
Pump-motor unit does not generate any or generates insufficient pressure difference.	Leak in system.	Seal leak in the system.	Operator
	Wrong direction of rotation.	Reverse direction of rotation by interchanging two connecting leads.	Electrician
	Incorrect frequency (on pump-motor units with frequency converter).	Correct frequency.	Electrician
	Shaft seal defective.	Replace shaft seal.	Service <sup>*)</sup>
	Different density of pumped gas.	Take conversion of pressure values into account. Inquire with Service Department.	Service
	Change in blade profile due to soiling.	Clean impeller, check for wear and replace if necessary.	Service <sup>*)</sup>
Abnormal flow noises.	Flow speed too high.	Clean pipes. Use pipe with larger cross-section if necessary.	Operator
	Muffler soiled.	Clean muffler inserts, check condition and replace if necessary.	Service <sup>*)</sup>
Abnormal running noise.	Ball bearing lacking grease or defective.	Regrease or replace ball bearing.	Service <sup>*)</sup>
Compressor leaky.	Seals on muffler defective.	Check muffler seals and replace if necessary.	Service <sup>*)</sup>
	Seals in motor area defective.	Check motor seals and replace if necessary.	Service

<sup>\*)</sup> Only when the maintenance manual is at hand: rectification by the operator.

### 9.3 Service/After-sales service

Our Service is available for work (in particular the installation of spare parts, as well as maintenance and repair work), not described in these operating instruction.

A list of spare parts with an exploded drawing is available on the Internet at [www.gd-elmorietschle.com](http://www.gd-elmorietschle.com).

Observe the following when **returning** pump-motor unit:

- The pump-motor unit must be delivered complete, i.e. not dismantled.
- The pump-motor unit may not present a danger to the workshop personnel. Each pump motor unit on delivery to the workshop must be accompanied with a fully completed "Statement on health safety and on the protection of the environment", Pg. 29.
- The original rating plate of the pump-motor unit must be properly mounted, intact and legible. All warranty claims are voided for pump-motor units delivered for a damage expertise without the original rating plate or with a destroyed original rating plate.
- In case of warranty claims, the manufacturer must be informed of the operating conditions, operating duration etc. and additional detailed information provided on request if necessary.

## 10 Disposal

Have the entire pump-motor unit scrapped by a suitable disposal company. No special measures are required when doing so.

For additional information on disposing of the unit, ask the Service Department.

## 11 Explosion-Protected Design

An additional set of operating instructions with supplementary or specific information is provided with these pump-motor units.

## EU declaration of conformity

**Manufacturer:** Gardner Denver Deutschland GmbH  
Industriestraße 26  
97616 Bad Neustadt  
Germany

**Responsible for documentation:** Holger Krause  
Industriestraße 26  
97616 Bad Neustadt  
Germany

**Designation:** G series Side channel blower  
G-BH1, G-BH9  
Types            2BH1 1 2BH1 2 2BH1 3 2BH1 4  
                     2BH1 5 2BH1 6 2BH1 8 2BH1 9  
                     2BH9 23

**The side channel blower described above meets the following applicable Community harmonisation legislation:**

**2004/108/EC<sup>1)</sup>** Directive 2004/108/EC of the European Parliament and of the Council of 15 December 2004 on the approximation of the laws of the Member States relating to electromagnetic compatibility and repealing Directive 89/336/EEC

**2006/42/EC** Directive 2006/42/EC of the European Parliament and of the Council of 17 May 2006 on machinery, and amending Directive 95/16/EC

The protection targets of the directive 2006/95/EC have been met

### Harmonised standards applied:

**EN 1012-1:2010** Compressors and vacuum pumps - Safety requirements - Part 1: Air compressors

**EN 1012-2:1996  
+A1:2009** Compressors and vacuum pumps - Safety requirements - Part 2: Vacuum pumps

**EN ISO 12100:2010** Safety of machinery - General principles for design - Risk assessment and risk reduction

**EN 60204-1:2006** Safety of machinery - Electrical equipment of machines Part 1: General requirements

Bad Neustadt, 26.09.2011

*(Place and date of issue)*

Thomas Kurth, Managing Director

*(Name and function)*

  
*(Signature)*

<sup>1)</sup> Only applicable for version with frequency converter 2FC

664.44434.40.000



**Statement on health safety and on the protection of the environment**

- For the safety of our employees and to comply with statutory requirements on handling substances harmful to the health and the environment, this statement must be enclosed, fully completed, with **each** unit/system sent.
- **Without the fully completed statement, repair/disposal is not possible and delays are unavoidable!**
- The statement is to be completed and signed by suitably qualified, authorised personnel at the operating organisation.
- In the case of shipment to Germany, the statement is to be completed in German or English.
- The statement is to be attached to the outside of the packing on shipment.
- If necessary, the carrier is to be informed.

1. **Product designation (type):** .....

2. **Serial number (no. BN):** .....

3. **Reason for sending:** .....

4. **The unit/system**

- has **not** come into contact with hazardous substances. There will be **no** hazards for personnel or the environment during repair/disposal. Continue with "6. Legally binding statement"
- has come into contact with hazardous substances. Continue with "5. Information on the contamination"

5. **Information on the contamination** (if necessary provide more information on an additional sheet)

The unit/system was used in the following application:

.....  
and has come into contact with the following classifiable substances or substances presenting a hazard to health/environment:

Trade name:	Chemical designation:	Hazardous substance class:	Properties (e.g. toxic, inflammable, caustic, radioactive):
.....	.....	.....	.....
.....	.....	.....	.....
.....	.....	.....	.....

- The unit/system has been emptied in accordance with the operating instructions, flushed and cleaned externally.
- Safety data sheets in accordance with the applicable regulations are enclosed ( ..... sheet).
- The following safety precautions are necessary for handling (e.g. personal protective equipment):  
.....  
.....

6. **Legally binding statement**

I herewith guarantee that the details specified are true and complete and that I, as signatory, am in a position to judge that this is so.

We are aware that we are liable to the contractor for any damages arising from incomplete or incorrect specifications. We are obliged to indemnify the contractor against claims for damages by third parties arising from incomplete or incorrect specifications. We are aware that, irrespective of this statement, we are directly liable to third parties - in particular including the contractor's employees tasked with repair/disposal.

Company/institute: .....

Name, position: ..... Phone: .....

Street: ..... Fax: .....

Post code, city: .....

Country: ..... Stamp: .....

Date, signature: .....

© Gardner Denver Deutschland GmbH

610.00250.40.905

P.O. box 1510

Phone: +49 7622 392 0

E-mail: er.de@gardnerdenver.com

10.2009

97605 Bad Neustadt

Fax: +49 7622 392 300

Internet: www.gd-elmorietschle.com

English

---

---



**Elmo  
Rietschle**  
*A Gardner Denver Product*

[www.gd-elmorietschle.de](http://www.gd-elmorietschle.de)  
[er.de@gardnerdenver.com](mailto:er.de@gardnerdenver.com)

**Gardner Denver  
Schopfheim GmbH**  
Roggenbachstraße 58  
79650 Schopfheim · Deutschland  
Tel. +49 7622 392-0  
Fax +49 7622 392-300

**Gardner Denver  
Deutschland GmbH**  
Industriestraße 26  
97616 Bad Neustadt · Deutschland  
Tel. +49 9771 6888-0  
Fax +49 9771 6888-4000

**Gardner  
Denver**

Elmo Rietschle is a brand of  
Gardner Denver's Industrial Products  
Group and part of Blower Operations.